



F L O O R L O O M

W O L F L O O M

M a i n t e n a n c e
&
W a r r a n t y

Schacht Spindle Co., Inc.
6101 Ben Place
Boulder, Co. 80301
USA
(303) 442-3212, 1-800-228-2553
FAX 303-447-9273

info@schachtspindle.com
www.schachtspindle.com

Caring for Your Schacht Loom

Thank you for choosing a Schacht loom. Great care has been taken in the design of your loom to make it efficient and sturdy, as well as aesthetically pleasing. Your loom is constructed with traditional woodworking joinery using materials which we have specially selected with their function in mind. We feel that sound design and quality craftsmanship, along with regular maintenance, ensure that your loom will give you continuous good service.

Throughout the manufacturing process each part has been inspected by several people. The final assembly of your loom has been done by one person who is very familiar with its workings. Should you have any questions about the quality of the work, please do not hesitate to contact either your dealer or our Customer Service Department. Your input is encouraged and has, over the years, contributed to the fine-tuning of our designs.

Your Schacht loom is a unique tool, and because of the nature of wood, each loom will be slightly different. At the same time, it is a precision machine with moving parts that require care and maintenance. The better you understand your loom, the more easily you will be able to take advantage of its features. Please read this short booklet before starting to weave on your loom.

Finding the Right Place for Your Schacht Loom

The correct placement of your loom is very important. We recommend that you place your loom on a carpet or rug. Not only will this provide quieter operation, it will also keep the loom more stable and prevent it from slipping around. Find a level place to put your loom. If the loom is not level, harnesses could possibly stick and the beater may be moved out of alignment causing irregularities in your weaving. If you notice any of these problems, try moving the loom around to different spots in the room where the floor may be more level.

The beater has been correctly set at our factory and should rest equally against the sides of the front beam when it is pulled forward. It is possible that the beater alignment was disturbed during shipment. If you find your beater needs adjusting, loosen (do not remove) the two bolts on either side of the beater race and the wing nuts on the beater top, bring the beater forward against the front beam and retighten the four bolts on the sides; then retighten the wing nuts on the beater top. If this doesn't correct the alignment, lift one or the other of the loom's legs and see if this balances the beater. If it balances, move your loom to a more level location, or place a shim under the leg to keep the beater balanced.

The Wood of Your Schacht Loom

All of our Standard Floor Looms are available in hard maple and cherry in the finest grades available. Our Wolf Pup, Baby Wolf and Mighty Wolf looms are crafted from hard maple. From time to time we offer these looms in cherry. All our wood is kiln dried to assure its stability under a variety of environmental conditions.

Maple is a strong and beautiful wood with an interesting character. It has a very fine grain which takes a high polish and is extremely resistant to abrasion. Cherry is one of the most beautiful woods of North America. As the wood ages it naturally darkens.

Try to keep your loom out of direct sunlight. It is also important to realize that shaded areas of your loom, such as those caused by leaving a warp on for long periods of time, will darken more slowly.

Wood is a natural, breathing material, and like any natural material, it is affected by its environment. Avoid placing your loom near direct heat sources such as heat vents, wood stoves, space heaters, and direct sunlight. Heat concentrated on parts of the loom can cause them to dry out and shrink. This shrinkage can cause weakness in the joints and warping of the parts. Likewise, place your loom where it will be free of very damp, moisture-laden air, as this can make the wood swell and cause the moving parts to stiffen and function inefficiently.

About the Finish on Your Schacht Loom

Your loom has been finished with Danish oil. This type of finish actually penetrates into the wood, protecting the wood as well as the surface area. If you need to touch up parts of your loom which have gotten chipped or scuffed, you can lightly sand the worn area with fine sand paper or steel wool and apply a small amount of finish using a soft, lint-free rag. Use either Watco or Deft natural Danish oil, which are available at most hardware stores. Follow the directions on the can for use and for proper rag disposal.

Taking Care of the Metal Parts

There are a variety of metal parts on your loom. We choose the type of metal for each part that is best suited to the specific demands made on it.

The aluminum parts will not rust, and those that require extra protection have been anodized. Certain steel parts have been plated. The reeds and heddle bars are stainless steel and require no special care, though reeds may need to be cleaned of debris before use.

Lubricating the Moving Parts

Your loom has numerous moving parts which are essential to its proper function. Periodic lubrication of all the sliding and pivoting pieces will keep them moving freely. Silicon spray is a fine lubricant that is easy to apply.

How much you weave will determine how often you need to lubricate your loom. A thorough going over at least twice a year is recommended. For production weavers, maintenance should be more frequent.

To keep the treadling action smooth and easy, spray the pivot pins which connect the lamms to the jacks and the pivot points of the

jack pins. Spraying silicon in the harness channels will keep the harnesses sliding up and down smoothly. If you find one harness consistently hanging up, inspect the harness as well as the harness tracks for rough spots and clean them as necessary with a rag or fine steel wool. Harnesses can become unbalanced when an excess of unused heddles are pushed to one side of the harness. It is best to try to distribute the heddles evenly (such as selective spacing of the unthreaded ones), or to take off the unused ones. When removing the heddles, be sure to place a strong string through the top and bottom holes of the heddles to keep them in order.

About your Friction Brake

The friction brake on the warp beam is designed to hold firmly by utilizing the friction between the cable and brake drum. DO NOT lubricate the brake cable and brake drum. If the brake is not releasing or tends to stick in spots, chances are that dirt or weaving fuzz has gotten between the cable and drum. Remove the cable (making sure you note which way the cable is wrapped so that you can replace it the same way) and wipe the cable and drum with a dry rag. If it is gritty, rub the brake drum with fine steel wool. Wrap the cable back around the drum and check to see that it releases easily.

If you are still having trouble, it will probably be necessary to make some adjustments to the brake. Refer to your set-up instructions to remedy this situation.

ALWAYS depress the brake pedal when you are winding on the warp as well as when you are advancing the weaving onto the cloth beam. Failure to do so will damage the brake drum by scoring the hub.

Further Information

For more information, visit our website at www.schachtspindle.com, click on "Instructions," and then go to the "Standard Floor Loom & Wolf Loom Troubleshooting" section.

Maintenance Notes

*Clean loom fuzz and your thrums from under the harnesses to prevent clogging of the jacks. To clean the jacks and lamms thoroughly, unscrew the nuts from the jack pins and pull the harnesses up and out of the loom.

*Periodically lubricate the moving parts. DO NOT lubricate the brake drum and brake cable.

*Touch up worn or chipped areas. Use very fine sandpaper or a Scotch-Brite pad (same as used for household cleaning) and Danish oil finish (follow the instructions on the can).

*Check screws for tightness from time to time. The action of weaving causes your loom to vibrate, and over time this action may loosen screws and nuts. Pivoting pieces such as the beater pivot points, the ratchet dog, the brake pedal, and the rear uprights need not be tightened as these parts have lock nuts on them and will not loosen. In humid climates the wood may swell, and you may find the lock nuts on these pivot points need to be loosened slightly.

*Clean any rust that appears with Naval Jelly.

*Proper care of your Schacht loom will increase its life-span. A simple schedule of regular maintenance and care will ensure your Schacht loom will perform well for years to come.

Floor and Wolf Loom Accessories and Enhancements

Floor Loom Enhancements

Sectional Beam
Double Back Beam
Lamp Holder
Raddle

Wolf Loom Enhancements

Wolf Pup
Trap
Raddle

Baby Wolf
High Castle Tray
Stroller
Height Extender
Sectional Beam
Double Back Beam
Trap
Raddle

Mighty Wolf
Stroller
Height Extender
Sectional Beam
Double Back Beam
Trap
Raddle

Two Year Limited Warranty

Your new Schacht Spindle Company Floor Loom is warranted, to the original consumer purchaser, by Schacht Spindle Company, Inc., to be free of defects in material and workmanship. Schacht Spindle Company's obligation under this Warranty shall be limited to the repair or replacement of any part or parts which may prove defective within two (2) years following the date of original new purchase by the consumer, and which Schacht Spindle Company's examination shall disclose to our satisfaction to be thus defective.

If a problem with this Schacht Spindle Company product develops during the warranty period, first contact the Schacht Spindle Company dealer from whom you made the purchase. If you need further assistance, please contact our Customer Service Department at Schacht Spindle Company. At our option, it may be required that the product be returned to our factory freight prepaid for inspection and repair and/or replacement.

This Warranty covers normal consumer use and does not cover damage which occurs in shipment or damage which results from alteration, accident, misuse, abuse, or neglect.

This Warranty gives you specific legal rights, and you may also have other rights which vary from state to state.

Your loom serial number is The serial number of your loom is stamped into the wood at the center of the Front Castle Cross Brace. If the serial number of your loom doesn't agree with the number written on this page, use the number stamped on your loom.

Low Castle Floor Loom (Rear View)

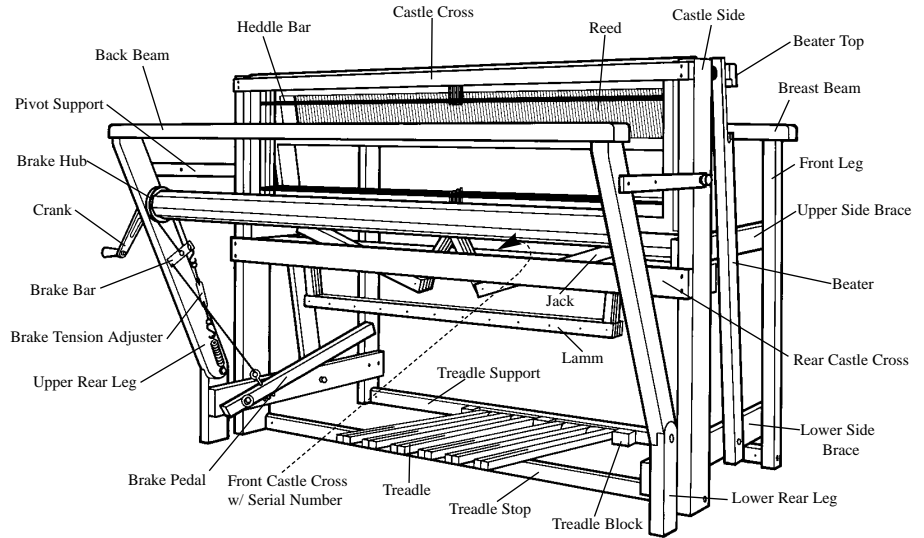

Wolf Loom (Rear View)

