

# FLIP™ LOOM

SL2013, SL2014  
SL2015, SL2016

WARPING & WEAVING



Flip Loom shown with optional Trestle Stand



Find out more at [schachtspindle.com](http://schachtspindle.com)  
Schacht Spindle Company 6101 Ben Place Boulder, CO 80301  
303.442.3212

© 2021 Schacht Spindle Company, Inc.

05.21

## PARTS

- 1X rigid heddle
- 3X apron bars
- 2X 3/16" dowels
- Apron cords:
- 6X for 15" loom
- 8X for 20" loom
- 10X for 25" loom
- 12X for 30" loom

For projects and additional information, visit [www.schachtspindle.com](http://www.schachtspindle.com)

## ACCESSORY PACK

- 2X lock knobs
- 2X loom clamps
- 1X warping peg & clamp (2X for 30" loom)
- 1X heddle hook
- 2X stick shuttles

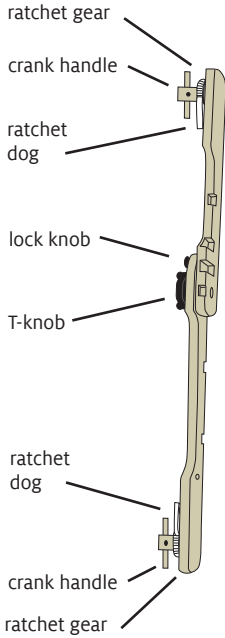
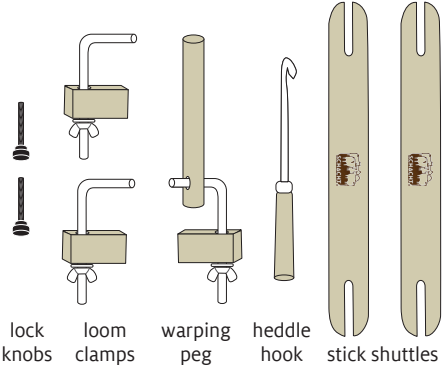

### BACK OF LOOM

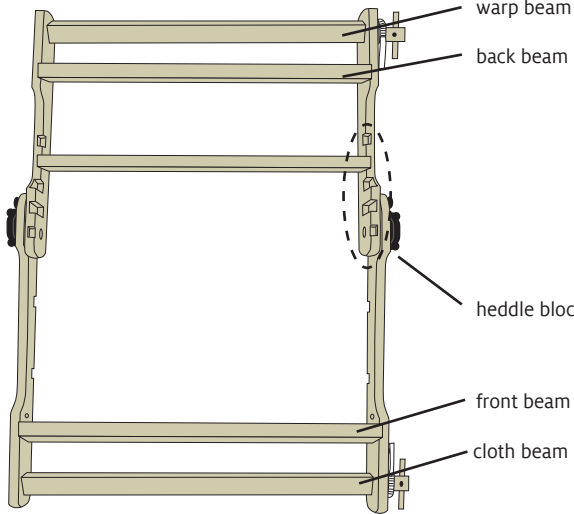

### FRONT OF LOOM

15" and 20" Flip looms have ratchet dogs, ratchet gears, and crank handles only on the right side.

25" and 30" Flip looms have ratchet dogs, ratchet gears, and crank handles on both sides of the loom.

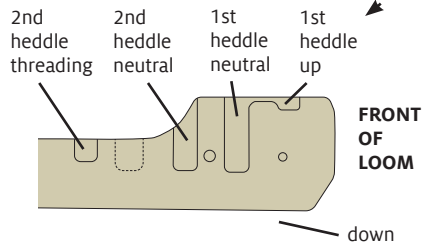

FIGURE 1: LOOM PARTS

FIGURE 2: HEDDLE SLOTS

# FLIP LOOM

Your new loom has been crafted from the finest hardwood maple, with each piece sanded and oiled by hand. Flip comes assembled. Install the apron bars and cords, and you're ready to warp and weave.

## UNFOLD FLIP

1. Loosen the T-knobs on each side of the loom (Figure 3A).
2. Pull on the cloth and warp beams to completely unfold the loom.
3. Insert the lock knobs on each side (Figure 3B).
4. Tighten all lock knobs and T-knobs.
5. Turn the loom over so it rests on its legs.

Directions for folding Flip are on page 11.

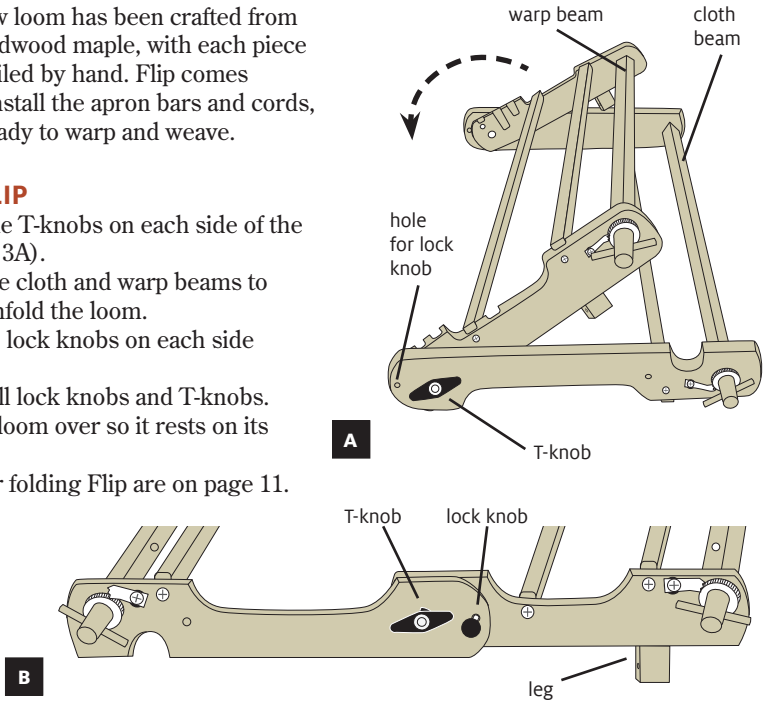

FIGURE 3: UNFOLD FLIP

## ATTACH THE APRON BARS

1. Attach the apron cords to the cloth and warp beams. Insert one end of a cord through a beam hole. Slide the 3/16" dowel through the first complete loop of an apron cord (Figure 4A). Repeat for the remaining holes on the beams.
2. Create a loop for the apron bar. Fold the cord about 4" from the free end and insert the fold through the first complete loop at the free end of the cord (Figure 4B).
3. Place the apron bar in the cord loop. Slide the apron bar through the loop (Figure 4B) and pull tight (Figure 4C).
4. Repeat Steps 2 and 3 for each cord. Three apron bars are included with your loom. The third bar is used for lashing on in certain warping methods.

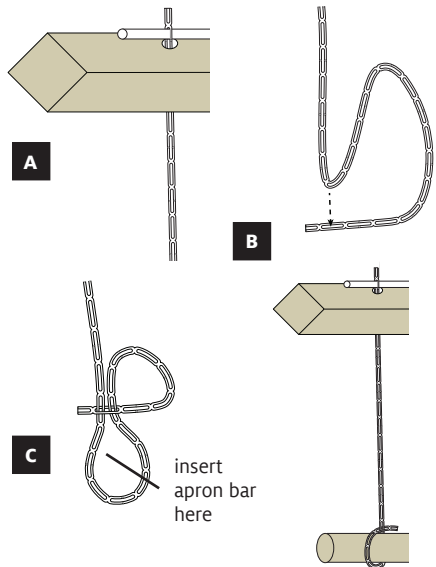

FIGURE 4: ATTACH APRON BARS

## WEAVING TERMS

**Balanced weave:** Fabric in which the number of warp ends per inch (see EPI) equals the number of weft ends, or picks, per inch (see PPI).

**Beat:** To push the weft threads into place with the rigid heddle.

**Cross:** The figure 8 made at one end of the warp when measured on a warping board. It keeps the warp ends in order and helps prevent tangles.

**End:** One warp yarn or thread.

**EPI:** Ends per inch. The number of warp threads, or ends, per inch, determined by the number of slots and holes per inch on the rigid heddle. Also called sett.

**Heddle block:** The notched area on the loom sides in which the rigid heddle rests.

**Loom waste:** The ends of the warp threads that are not usable because they are knotted onto the loom or remain unwoven.

**Pick:** One pass of the weft yarn through the shed.

**PPI:** Picks per inch. The number of rows of weft per inch.

**Plainweave:** The most basic weave in which the weft is woven over and under, over and under warp threads. Also called tabby.

**Rigid heddle:** The loom part made up of alternating slots and holes. It spaces the warp ends, creates sheds, and is used to beat the weft.

**Selvedge:** The edge threads on a piece of woven fabric.

**Shed:** The space between raised and lowered warp threads through which the weft passes.

**Shuttle:** A tool for holding and carrying weft.

**Take-up:** The amount of warp and weft length "lost" during weaving. The yarns, instead of going in a straight line, actually curve over and under each other, and therefore extra yarn is required.

**Warp:** As a noun, the set of threads held taut by the loom. As a verb, the process of threading the warp onto the loom.

**Weft:** The threads interlaced with the warp threads.

## QUICK GUIDE TO WARP & WEFT CALCULATIONS

Let's say you're going to weave a table runner that is 16" wide and 40" long.

**A. Calculate the length of your warp.** The length of the finished piece is 40", but you will also need additional warp length for tying onto the loom and other loom waste. The average loom waste is approximately 24". You should also add another 10% (4") for take-up, which is the amount of warp length "lost" during weaving. It is a good idea to add another 10% (4") for possible shrinkage when washing the fabric after weaving. Add these four numbers to get the total length required for the warp:

$$\begin{array}{r} 40" \text{ (length of piece)} \\ 24" \text{ (loom waste)} \\ 4" \text{ (take-up)} \\ 4" \text{ (shrinkage)} \\ \hline 72" \text{ (total length)} = 2 \text{ yards} \end{array}$$

**B. Determine the ends per inch (EPI).** There is a rule of thumb which is quite useful: simply wind the yarn you want to use as warp around a ruler for 1" so that there are no spaces between wraps. Then count the number of wraps in this 1" and divide by 2 for the number of ends per inch. Choose the heddle which comes closest to this number. In our example, the warp yarn is set at 10 EPI.

**C. Calculate the total number of warp ends.** Multiply the width of your planned weaving times the EPI to get the total number of warp ends. In our example: 10 EPI x 16" weaving width = 160 total ends of warp yarn.

**D. Calculate the total amount of warp (in yards) needed.** Finally, to figure how many yards of warp you will need, multiply the 160 total ends by 2 (the length of each warp end in yards). In our example, you will need a total of 320 yards for warp. Here's the simple formula (steps C and D above):

$$\text{Total warp ends} \times \text{length of warp (in yards)} = \text{total yards of warp}$$

**E. Calculate the weft yarn.** The amount of weft yarn you will need is determined by how firmly you beat your weft. For a balanced weave (the same number of wefts per inch as EPI), you'll need the same amount of weft and warp. For a weft-faced weave (where weft packs tightly and covers the warp), allow up to 5 times more weft than warp.

## CHOOSE YOUR WARPING METHOD

There are two ways to warp your loom, the **direct method** using a warping peg and the **indirect method** using a warping board. If you have never woven on a rigid heddle loom before, the direct method is a quick and easy way to begin.

The direct method, developed by Rowena Hart, allows you to measure your warp and thread the slots in the rigid heddle in one step. It is best for short warps, single-color warps, or stripes involving even numbers of warp ends. The indirect method is more versatile: it can accommodate longer warps, multiple colors, and any color order. The warp is measured on a warping board, then brought to the loom for threading. Directions for this method start on page 7.

## DIRECT WARPING WITH A WARPING PEG

**NOTE:** Illustrations here show the loom and warping peg clamped to a clear work surface to make all the parts visible. The loom and peg are positioned for a very short warp. Clamp your warping peg to a separate work surface and move it farther away from the loom to make a longer warp.

### Thread the slots

1. Calculate the length of your warp, warp width, and number of warp ends—see “Quick Guide to Warp & Weft Calculations” on page 4.
2. Set up your loom as shown in Figure 5:
  - Insert the metal part of the clamps into the holes in the legs. Clamp the loom securely to a work surface.
  - Set the rigid heddle in neutral position, in the second slot from the front.
  - Bring the back apron bar up **over** the back beam toward the heddle. Make sure you’ve gone over the back beam, not under it, or you will not get a shed.
3. Set up the warping peg: Clamp the warping peg in front of the loom, as far away from the back apron bar as your desired warp length (Figure 5).  
**Note for 30" looms: When warping the full width (or close to it), use 2 warping pegs to keep the warp ends more even. Divide the width of the warp in half and use a warping peg for each half.**
4. Set up the warp yarn: tie the yarn to the back apron bar and set the skein or cone behind the loom, so the yarn comes up over the back beam (Figure 5).

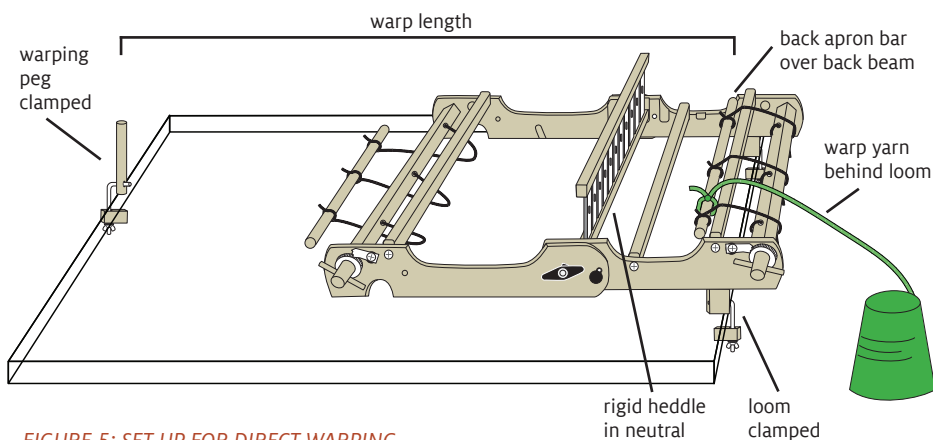

FIGURE 5: SET UP FOR DIRECT WARPING

**NOTE:** Here we're working from the right to the left of the loom (as viewed from the front). You can work from left to right if you prefer.

5. Find the center of the heddle and then measure out to one side half the width of your warp. For example, if your warp is 6" wide, measure out 3" from the center and begin threading at this point.
6. Insert the heddle hook through this slot and pull a loop of warp yarn through it, going **over** the apron bar (Figure 6A). Make sure to use a slot, not a hole, in the heddle. Place the loop of yarn on the warping peg (Figure 6B). You have now measured and threaded 2 warp ends through a single slot.
7. Continuing along the apron bar, pull another loop of yarn **under** the apron bar (to encircle the rod) and through the next slot in the rigid heddle. Place the loop over the warping peg (Figure 7). Continue pulling the loops over and under the apron bar until all the warp ends have been measured. Each loop on the warping peg equals 2 warp ends.
8. Cut off the yarn from the ball or cone and tie to the back apron bar (Figure 8).

**Wind the warp onto the warp beam**

9. Hold all the loops on the warping peg in one hand and lift them off the warping peg (Figure 9A). Cut the end of the loops with sharp scissors (Figure 9B). Tie the bundle of warp threads into a loose overhand knot and set aside.
10. Wind the warp onto the warp beam by turning its crank handle(s) clockwise. When the warp has been rolled around the beam once, insert heavy paper between the layers of warp threads to separate them. As you wind the warp on the beam, insert more paper to maintain separate layers.
11. Continue rolling the warp and paper onto the warp beam. Stop every so often to pull hard on the knotted end of the warp to tighten the paper and warp on the beam.
12. Stop winding when the front end of the warp is about 10" from the heddle. Untie the knot.

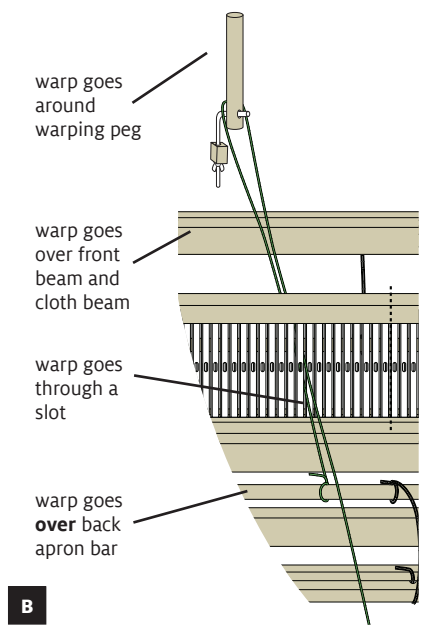
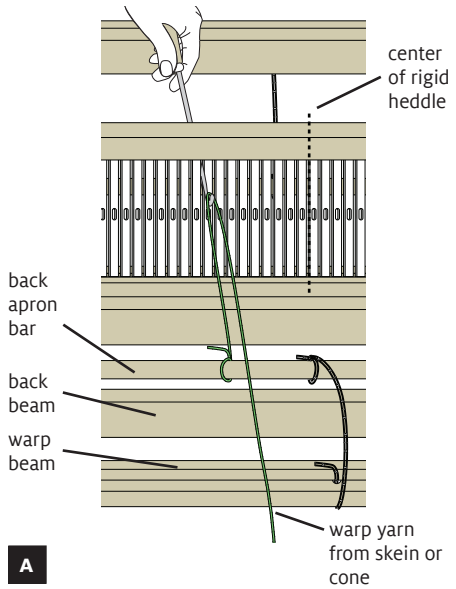

**FIGURE 6: FIRST LOOP**

### Thread the holes

**13.** When you threaded the slots, you placed 2 warp ends in each slot. Now you'll take 1 end out of each slot and thread it through the adjacent hole using your heddle hook (Figure 10A). Work from one edge of the weaving to the other until all holes have been threaded (Figure 10B).

### Tie onto the front apron bar

**14.** Bring the front apron bar around and **over** the front beam so that it is about 6" from the heddle. Make sure you've gone over the front beam, not under it.

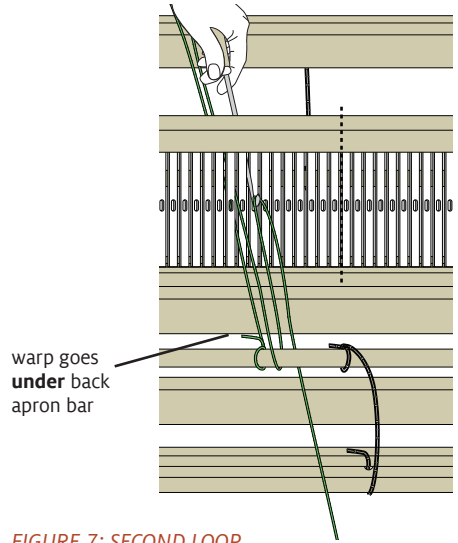

FIGURE 7: SECOND LOOP

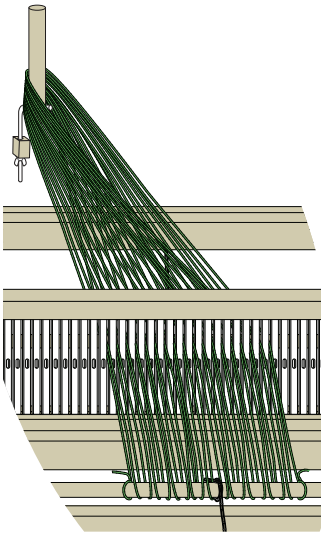

FIGURE 8: ALL SLOTS THREADED

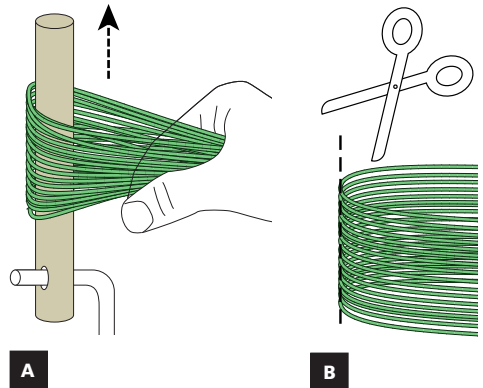

FIGURE 9: REMOVE WARP FROM PEG

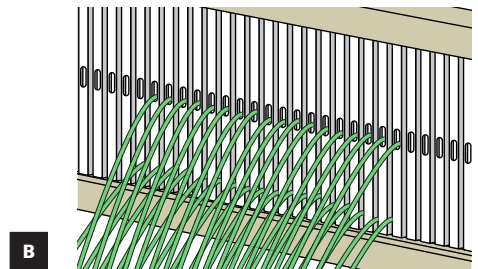
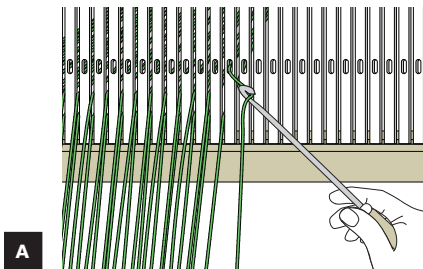

FIGURE 10: THREAD THE HOLES

**15.** Select a group of threads about 1" wide at the center of the warp and bring them over the top of the apron bar, dividing them in half and tying together around the apron bar using a surgeon's knot (Figure 11A). It's like starting to tie your shoes, except the threads go around twice.

**16.** Alternate tying 1" groups to the right and left of center until all groups are tied.

**17.** Work back and forth across the warp, tightening all the groups. Start in the center and work outwards on each pass. Pat across the warp to check if all groups have equal tension. The tension should be even, but doesn't need to be very tight. (Once the warp is evenly tensioned, you can increase the weaving tension as needed.)

**18.** Secure the ends of each group with a bow or square knot (Figure 11B). You are now ready to weave—go to page 10.

## INDIRECT WARPING WITH A WARPING BOARD

### Set up the warping board

**1.** Calculate the length of your warp, warp width, and number of warp ends (see page 4).

**2.** Cut the guide string a few inches longer than your warp length. Tie one end around the left cross peg, as shown in Figure 12. Pass the guide string under the right cross peg, then outside the next closest peg.

**3.** Work back and forth around remaining pegs on the board, adjusting which pegs to use until the end of the guide string ends close to a peg. (Use more pegs for a longer warp or fewer pegs for a shorter one.) Tie the guide string around this peg—it's now the starting peg.

### Wind the warp

**4.** Tie the warp yarn to the starting peg. Follow the guide string to the cross pegs. Wind a figure 8 around these pegs, as in Figure 13—this forms the cross to keep the warp ends in order. Follow the guide string back to the starting peg.

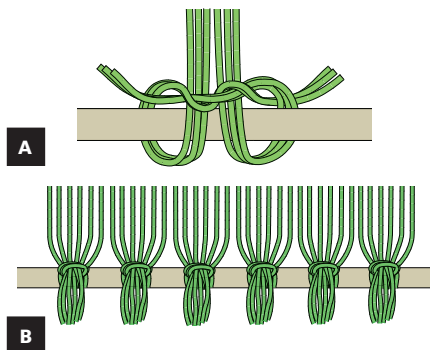

FIGURE 11: TIE ONTO FRONT APRON BAR

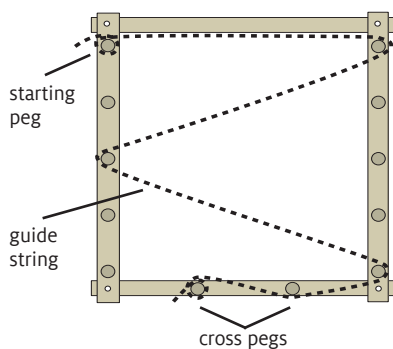

FIGURE 12: SET UP THE GUIDE STRING

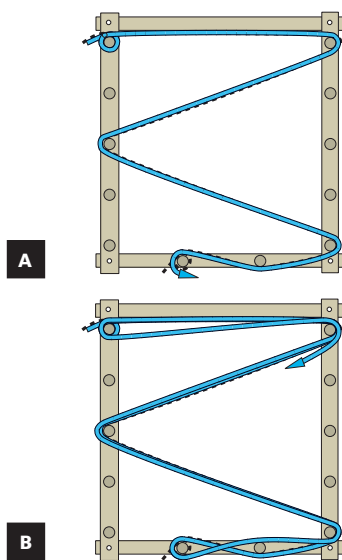

FIGURE 13: MEASURE THE WARP



5. Continue winding from the starting peg to the cross pegs and back, until the total number of warp ends are measured (Figure 13). Every loop around the starting peg equals 2 warp ends. Cut the yarn and tie it around the starting peg.

#### Remove the warp from the warping board

6. Secure the cross in five places with loose cross ties, as in Figure 14, using contrasting scrap yarn and overhand knots. Tie choke ties in a second color of scrap yarn, placing them at about 18" inch intervals down the length of the warp chain. Tie all choke ties with tight bow ties to keep the chain from tangling.

7. Remove the chain from the warping board. Cut the non-cross end of the chain and tie the ends in an overhand knot.

#### Thread the heddle

8. Temporarily secure the warp chain around the front beam, leaving the cross end long enough to reach the back beam.

9. Place the heddle in the 1st heddle neutral slot (Figure 15). Find the center of the heddle and then measure out to one side half the width of your warp. For example, if your warp is 10" wide, measure out 5" from the center and begin threading at this point. (You can thread from right to left or left to right.)

10. Hold the cross in your non-dominant hand, separating each section as in Figure 16. Cut the loops at the end. Remove the cross ties—do not cut the warp yarn. Notice that the ends stack up Lincoln-log style.

11. Position your cross hand in front of the reed. Hold the threading hook in your dominant hand; position this hand behind the reed. Starting at the outermost edge of your weaving, pick up the top warp end from the cross and thread it through the slot. Thread the next end through the adjacent hole. Alternately thread slot, hole, slot, hole until all warp ends are threaded.

12. Tie groups of warp ends about 1" wide in overhand knots across the entire warp. Then tie each group around the back

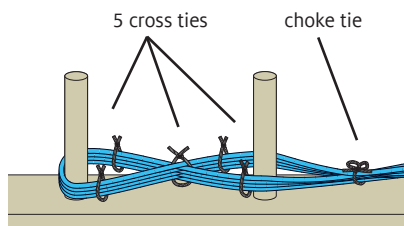

FIGURE 14: SECURE THE WARP AND THE CROSS

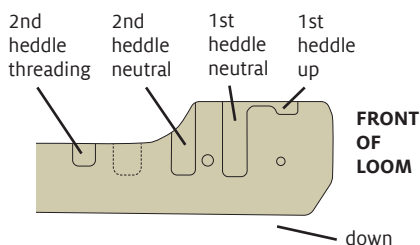

FIGURE 15: HEDDLE SLOTS

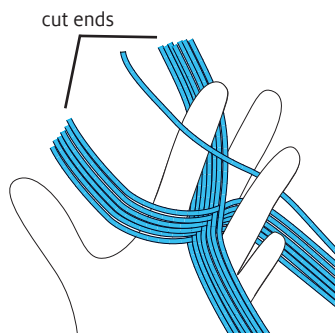

FIGURE 16: HOLD THE CROSS

apron bar and secure this second knot by tightening it up to the first knot (Figure 17).

**13.** Wind the warp onto the warp beam as described for the direct warping method.

**14.** Tie onto the front apron bar as described for the direct warping method. You are now ready to weave.

## WEAVING

The first shed is made by resting the heddle on the heddle block in the 1st heddle up position (Figure 18). This is called the up shed.

The down shed is made by bringing the heddle toward the front of the loom, then pushing down and sliding the bottom bar of the heddle underneath the front of the heddle block—tension on the warp holds the heddle in place. If the heddle will not stay in place, tighten your warp.

### Weave a header

Before beginning your project, weave a header with scrap yarn (Figure 19). It will spread the warp out evenly so that your weaving project can begin on an even, uniform warp. Use scrap yarn about the same size as your project yarn. Weave 3 rows without beating and then press these in place with the rigid heddle. Repeat if needed until the warp is evenly spread.

### Wind a shuttle

You will need a shuttle for weaving. A stick shuttle about the same width as your warp works well on the rigid heddle loom. Wind the weft yarn around the shuttle in a figure 8. You can wind along one edge or both edges of the shuttle (Figure 20).

### Weave your project

To weave fabric on your loom, you'll alternate raising and lowering the rigid heddle as the weft yarn travels from right to left, then left to right. On the first pick, place the rigid heddle in up position and pass the shuttle through the up shed. On the second pick, place the rigid heddle in down position and pass the shuttle through the down shed. Repeat these picks to interlace warp and weft threads.

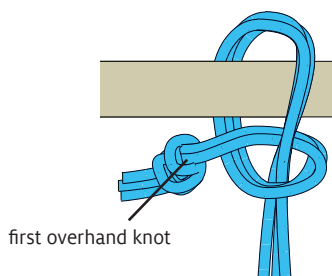

FIGURE 17: TIE ONTO BACK APRON BAR

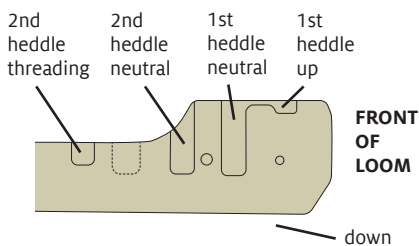

FIGURE 18: HEDDLE SLOTS

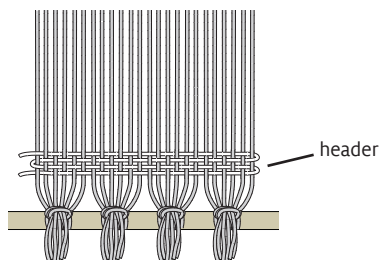

FIGURE 19: WEAVE A HEADER

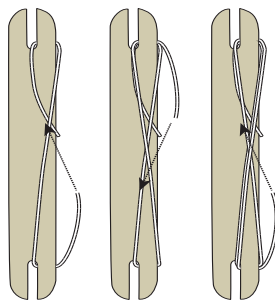

FIGURE 20: WIND A SHUTTLE

Beat the weft into place with the rigid heddle and then weave the opposite shed, returning the shuttle to the other side of the weaving.

As weft yarn comes off the shuttle, lay it at about a 30° angle so that it doesn't draw in your selvages (Figure 21). Your weft should be snug at the selvedge but should not pull in.

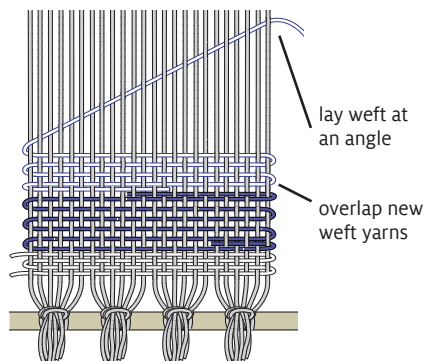

FIGURE 21: WEAVE YOUR PROJECT

### Advance the warp

After you have woven a few inches, you will notice that you have less room for the shuttle. Disengage the rear ratchet dog(s) by turning the rear crank handle(s) toward you and pulling up on the ratchet dog(s). On the 25" and 30" Flip, do this on both sides.

Turn the front crank handle(s) toward you until the woven edge of your cloth is 2" to 3" away from the front beam. Push the ratchet dog(s) back down on the ratchet gear(s). If the warp is not tight enough, turn the rear crank handle(s) away from you to tighten. Your woven cloth will be more consistent if you advance the warp about every 2".

**If a ratchet dog will not rotate easily, do not force it. Instead, loosen the screw that attaches it with a 7/16" (or adjustable) wrench and a #2 Phillips screwdriver. Hold the lock nut inside the loom with the wrench, then loosen the screw slightly with the screwdriver.**

### Remove your project from the loom

When you can't weave any farther or have finished your project, weave a few rows with waste yarn and cut the warp off from the back of the loom. Unwind the fabric from around the cloth beam and untie or cut off the warp from the front apron bar. **Be careful not to cut the apron cords.**

For finishing techniques, see the references listed at the end of this manual.

### FOLDING FLIP

If the loom is unwarped, reverse the steps in "Unfolding Flip" on page 3. If the loom has been warped, follow these steps:

1. Loosen the tension on the warp (just as you do to advance the warp) by one full turn of the ratchet gear(s). Replace the ratchet dog(s), and turn the crank handle toward you just enough to re-engage the ratchet dog(s).
2. Remove the rigid heddle from the heddle block and lay it flat toward the back of the loom, with its bottom edge in the 2nd heddle neutral slot (the third slot from the front of the loom; see Figure 18).
3. Loosen the T-knobs. Loosen the lock knobs enough to allow the loom to fold.
4. Pull up on the T-knobs to fold the loom. Tighten the T-knobs to keep the loom in the folded position.
5. Adjust the tension on the warp if needed to keep it in place.

### THREADING TWO HEDDLES

1. Measure the warp as described for indirect warping. We don't recommend the direct method with two heddles.
2. Secure the warp chain to the front beam for threading front to back.
3. Place a heddle in the 1st heddle neutral slot (see Figure 18). This is Heddle 1. Position the loom to work from the front. With a pencil or scrap yarn, mark a starting slot that centers the warp in the heddle.

4. Begin threading in the hole **next to** this slot (Figure 22). Thread all across the heddle in this way: 1 thread in a hole, 3 threads in a slot.

5. After you've threaded Heddle 1, turn the loom around to work from the back of the loom, as in Figure 23.

6. Insert Heddle 2 in the threading slot at the back (see Figure 18 on page 10). Count the slots from the edge of Heddle 1 to the first selvedge thread going through a hole. Now count the same number of slots in Heddle 2 and mark this slot.

7. As you thread Heddle 2, think in terms of 4-end groups. Take the ends from the first hole and slot—4 total ends—of Heddle 1. Find the corresponding hole in Heddle 2 and place the hole end and one of the slot ends in the slot to the **left** of the starting point (Figure 23A). You now have 2 ends left: thread one of them in the hole and the last one in the slot to the right (Figure 23B).

8. Thread across Heddle 2 in the same way, working in 4-end groups. Except for the selvages, there will always be 1 end in a hole and 3 in a slot. Check your work as you go. Any thread going through a hole can only go through the hole in one heddle; it must go through a slot on the other heddle.

9. Tie onto the back beam, beam the warp, and tie on to the front beam.

10. To weave with two heddles, you can use each heddle separately or you can hold them together. When you weave with Heddle 2 on its own, use the following steps for down position: Move Heddle 1 forward out of the way, slide Heddle 2 under the heddle blocks, then lift Heddle 1 until its hole threads are even with the other raised threads. Slide the shuttle through the shed and beat. ■

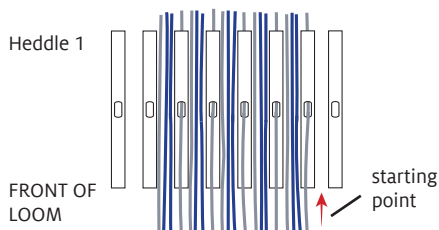

FIGURE 22: THREADING HEDDLE 1

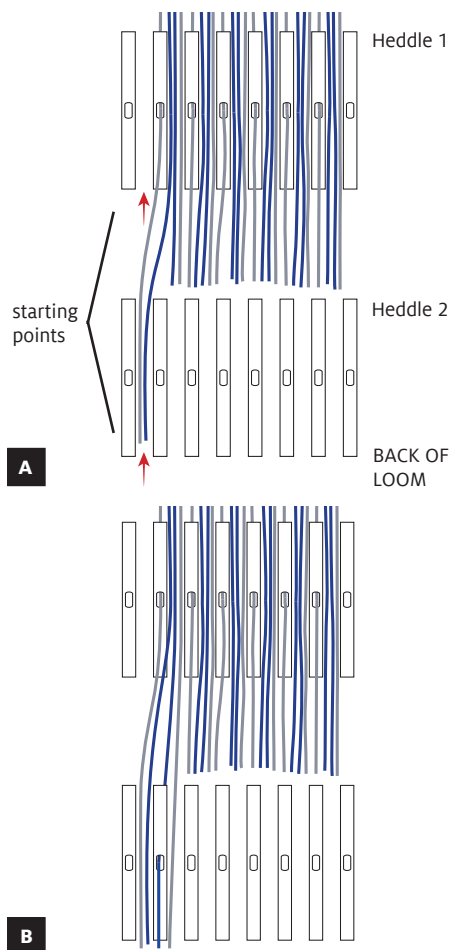

FIGURE 23: THREADING HEDDLE 2

## RESOURCES

Gipson, Liz. *Weaving Made Easy*. Interweave, 2008.

———. *Handwoven Home*. Interweave, 2017.

Patrick, Jane. *The Weaver's Idea Book*. Interweave, 2010.

———. *Rigid Heddle Weaving* (video). Interweave, 2011.