

## Special Instructions for Installing Apron Rods for Cherry Wolf Looms

*Note: These instructions replace those in the Assembly Instruction Leaflet .*

You will use for each beam:

- One long piece of Texsolv cord
- One 1/4" dowel
- One apron bar

Begin with the warp beam, as follows:

1. Insert an end of the 1/4" dowel through the second loop from the end of the Texsolv cord.
2. Thread the free end of the cord through the outermost hole on one end of the warp beam. Pull the cord through the hole until the cord and the dowel are snug against the warp beam (Diagram A).
3. Pass the cord around the apron bar leaving about 30" between the warp beam and the apron bar. Bring the cord back to the warp beam and insert it in the return direction through the next hole in the beam. Loop the cord around the dowel and thread it back through the same hole.
4. Continue to thread the cord around the apron rod and through the beam in this manner until you reach the end of the beam.
5. Thread the cord into the last hole on the beam and insert the other end of the 1/4" dowel into the second loop from the end of the cord.
6. Repeat for the cloth beam.

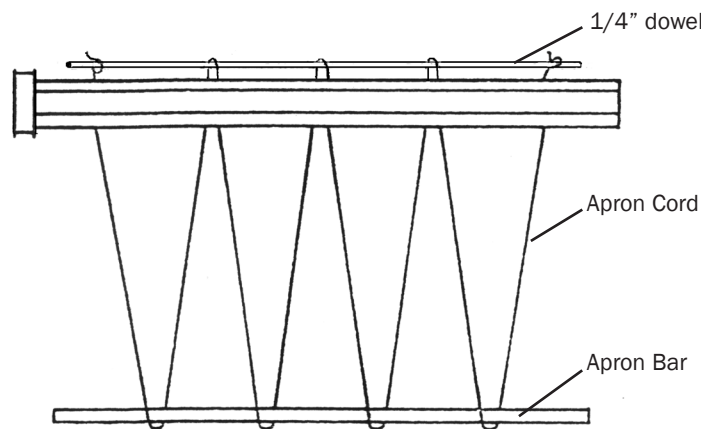

Diagram A