

HAND BOBBIN WINDER

ASSEMBLY INSTRUCTIONS FOR SINGLE-END AND DOUBLE-END WINDERS

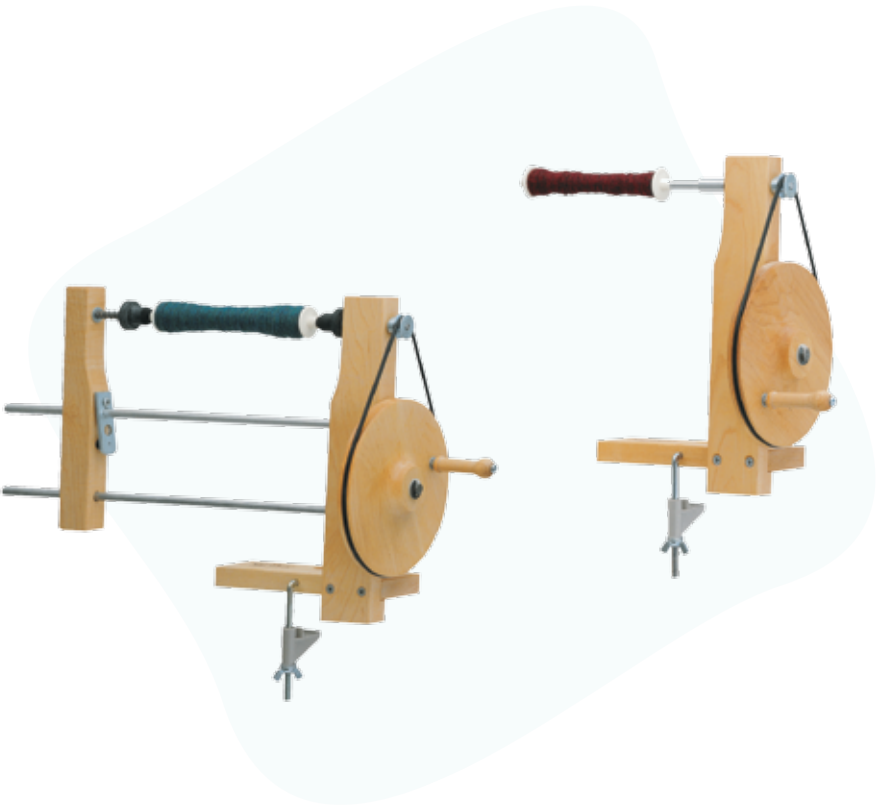

Find out more at schachtspindle.com
Schacht Spindle Company 6101 Ben Place Boulder, CO 80301
p. 303.442.3212 800.228.2553 f. 303.447.9273

HAND BOBBIN WINDER

ASSEMBLY INSTRUCTIONS

Your hand bobbin winder has been carefully designed for years of trouble-free use. The bearings are all self-lubricating and should not require further lubrication under normal use. If your bobbin winder becomes difficult to turn in the future, a few drops of light

machine oil (sewing machine oil) on each bearing will help. Each bobbin winder has been carefully assembled and tested before shipping, then disassembled for shipping. The assembly instructions for both models follow.

SINGLE-END BOBBIN WINDER

Parts:

- 1 - main upright assembly
w/tapered metal shaft
- 1 - drive wheel assembly
- 4 - 3/8" washers
- 1 - 3/8" E-Clip
- 1 - drive belt
- 1 - 5/64" S.A. hex wrench

1. Clamp the bobbin winder to a table top. Place two 3/8" washers on the drive wheel axle. Place the drive wheel on the axle. Place two more washers on the drive wheel axle and secure the wheel in position by press-

ing the E-clip into the groove on the end of the axle (figure 1). If the groove in the axle is covered by one of the washers and you cannot press the E-clip into position, remove one of the washers. If the wheel does not turn freely after installing two washers on the outside, remove one of the washers.

2. Place the long tapered shaft on the short shaft at the top of the upright. Line up the flat side of the shaft with the set screw.

3. Tighten the set screw securely with the hex wrench. Install the rubber drive band around the shaft pulley and the drive wheel (figure 2), and you are ready to use your bobbin winder.

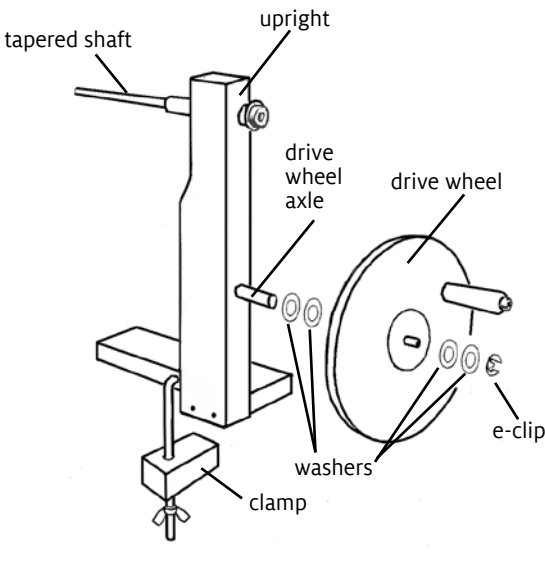

Figure 1

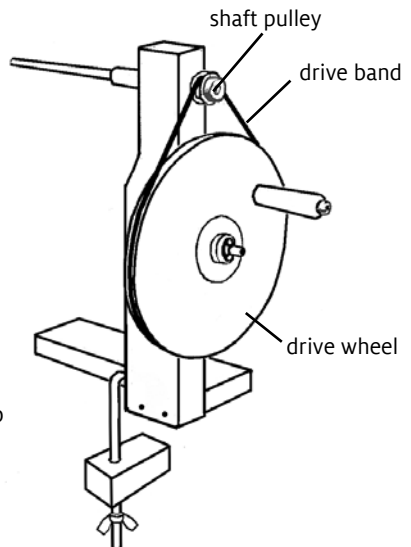

Figure 2

DOUBLE-END BOBBIN WINDER

Parts:

- 1 - upright assembly
w/aluminum tip
- 1 - tail spindle assembly
w/live center
- 1 - drive wheel assembly
- 4 - 3/8" washers
- 1 - 3/8" E-Clip
- 1 - drive belt
- 2 - 5/16" x 15" metal rods

1. Place the bobbin winder on its side on a corner of a sturdy table. The large axle on the drive wheel should be pointing toward the ground. Tap one end of the 5/16" metal rods into the two holes on the bobbin winder upright. Use a hammer with a piece of wood to tap the rods in place in order not to damage the ends of the metal rods. When the rods are

in all the way, they should extend about 13 1/2".

2. Place the tail spindle on the two metal rods by pressing the spring clamp toward the tail spindle and sliding the spindle onto the metal rods. The tapered tips on the bobbin winder should face each other (figure 3).

3. Clamp the bobbin and spool winder to a table top and install the drive wheel and rubber drive band as in the instructions for the single-end bobbin winder.

4. Adjust the tail spindle to fit your bobbins, spools, or pirns by pressing the spring clamp and adjusting the position of the tail spindle on the metal rods. The bobbin winder wheel will turn easily when there is as little tension as possible on the tail spindle. Experimentation will show you what is best for the type of winding you are doing. ■

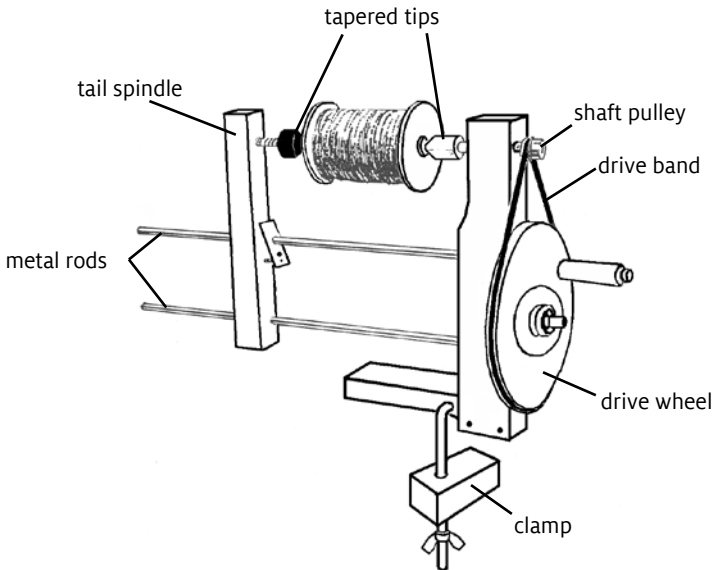

Figure 3

HELPFUL HINTS FOR USING YOUR BOBBIN WINDER

If your drive belt ever stretches out of shape and slips, this is easily remedied by stretching a rubber band over the groove in the wheel.

You can also increase belt tension and traction by twisting the belt once, so that it will make a figure 8, before placing it over the shaft pulley. Note that this will also reverse the direction you are winding.

You can order a replacement drive band, part number P400038. Call or email to order.