

SCHACHT-REEVES SAXONY SPINNING WHEEL

INSTRUCTIONS, MAINTENANCE
& WARRANTY



Find out more at schachtspindle.com
Schacht Spindle Company 6101 Ben Place Boulder, CO 80301
p. 303.442.3212 f. 303.447.9273

© 2011 Schacht Spindle Company, Inc.

05.11

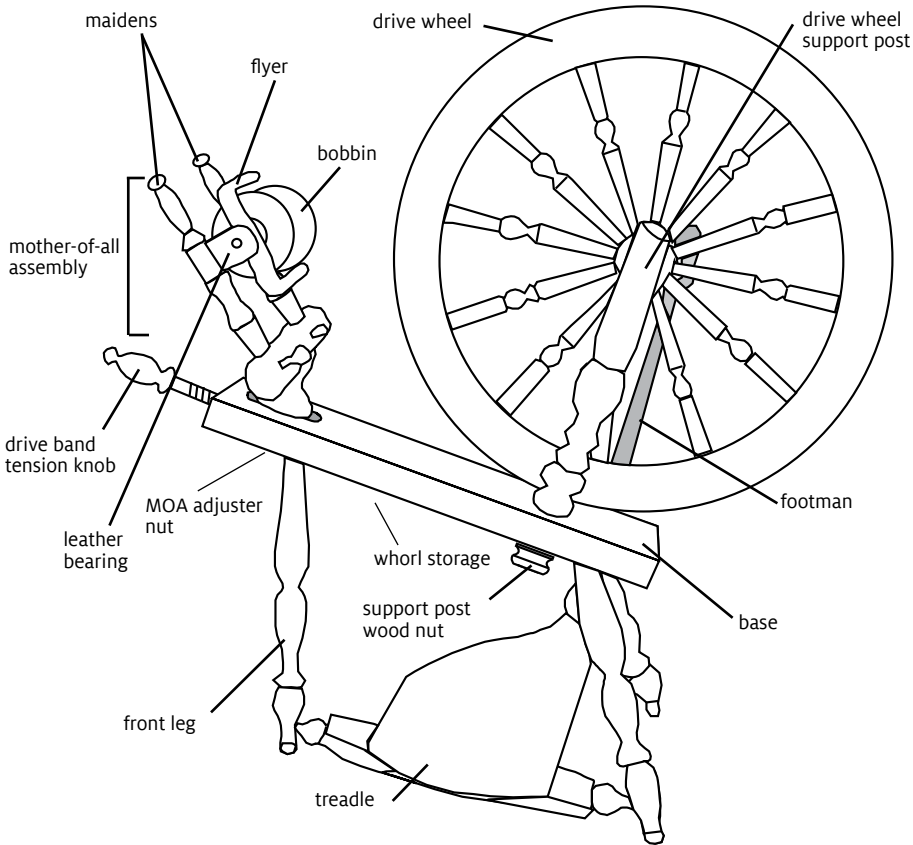

SCHACHT-REEVES WHEEL PARTS

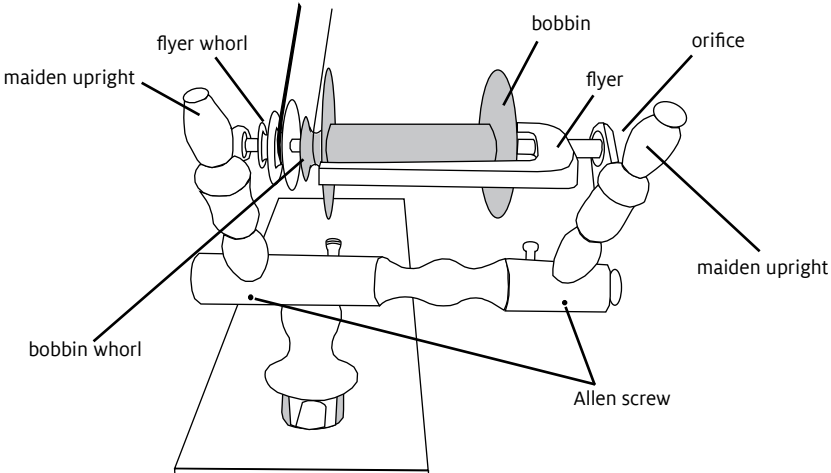

FLYER ASSEMBLY PARTS

SCHACHT-REEVES SAXONY SPINNING WHEEL

Thank you for choosing the Schacht-Reeves Spinning Wheel. We trust that it will give you many pleasurable and productive hours of spinning. We have taken great care in making your wheel using traditional woodworking joinery and methods. We have inspected all the parts for quality, and the final assembly has been completed by a skilled craftsman. Should you have any questions about the quality of the work or the materials, please do not hesitate to contact your dealer or our customer service department.

Your Schacht-Reeves Spinning Wheel is a precision tool with many moving parts that require regular care and maintenance. The better you understand your wheel, the better able you will be to take advantage of its many features.

Please read this booklet before you start spinning.

PARTS

Shipping Box

- Wheel assembly

- Wooden base assembly with 2 legs attached

Small Interior Box for 24" wheels or

Bubble Wrap Packages for 30" wheels

- Mother-of-all assembly

- Rosewood peg and thumbscrew

- Flyer assembly

- Wooden drive band tension knob

Large Interior Box

- Lazy kate with 3 bobbins

- Wooden leg with 1½" Phillips screw

Small Parts Bag

- Drive band

- Scotch tension spring and string

- Allen wrench

- Threading hook

ASSEMBLY INSTRUCTIONS

STEP 1. UNPACK THE WHEEL

Unpack the wheel and check that you have received all the parts.

STEP 2. ASSEMBLE THE BASE OF THE WHEEL

Place the base upside down on a table. Remove the 1 ½" Phillips screw temporarily from the leg. Insert the end of the leg into the base. Place the Phillips screw back in the hole in the leg and twist the leg so the screw aligns with the countersunk hole in the base. Screw the Phillips screw firmly through the leg into the base. Turn the base upright.

The treadle is not shown in the diagram in order to show the leg attachment more clearly.

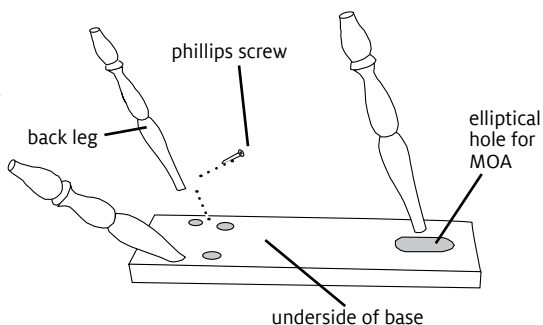

ASSEMBLE THE BASE

STEP 3. ATTACH THE WHEEL ASSEMBLY

Remove the 2 wooden nuts from the bottom of the drive wheel support posts. Attach the wheel assembly to the base by inserting the threaded ends of the two drive wheel support posts through the two holes on the top face of the base. Fasten each support post with a wooden nut on the underside of the base.

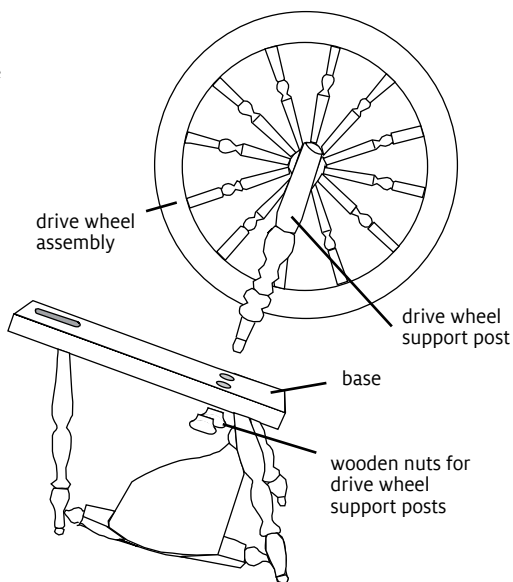

ATTACH THE DRIVE WHEEL ASSEMBLY

STEP 4. ATTACH THE MOTHER-OF-ALL (MOA) ASSEMBLY

Remove the MOA nut from the bottom of the MOA assembly. Place the MOA assembly, with the leather bearings facing the drive wheel, into the elliptical hole in the front of the base. Insert the drive band tension knob through the hole in the front of the base and into the screw hole in the block at the bottom of the mother-of-all assembly. Turn the tension knob clockwise until the mother-of-all is positioned approximately 1/3 of the distance from the lower end of the elliptical hole. On the underside of the base, secure the MOA assembly with the MOA nut.

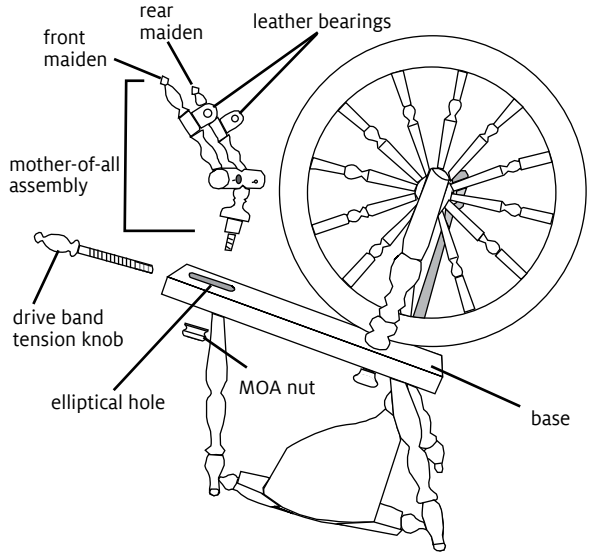

STEP 5. INSTALL THE DRIVE BAND FOR DOUBLE DRIVE MODE

Unwind the doubled drive band from the wheel and place the band in the drive wheel grooves.

Loosen the Allen screws located in the MOA below the maidens using the supplied Allen wrench. Pivot the front maiden outward to remove the flyer from the MOA (keeping the whorl and bobbin in place). Place the drive band over the flyer assembly. Replace the flyer in the MOA by fitting the whorl end of the flyer into the leather bearing on the rear maiden, then at the same time, inserting the orifice end of the flyer into the leather bearing on the front maiden and adjusting the front maiden inward to its original position. Check to be sure the flyer turns freely. To secure the maidens in place, tighten the Allen screws.

Place one loop of the drive band over the flyer whorl and the other loop over the bobbin whorl. Check to be sure the drive cord is still in the drive wheel slots.

ATTACH THE MOA ASSEMBLY

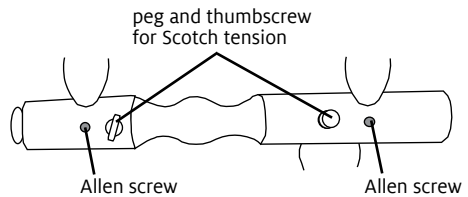

To adjust the drive band tension, first loosen the MOA nut on the underside of the base, then turn the drive band tension knob to loosen or tighten the drive band. When the tension is set, tighten the MOA nut to secure the MOA.

STEP 6. ALIGN THE DRIVE WHEEL

Slightly loosen the nut holding the MOA and the nuts holding the two drive wheel support posts. Align the drive wheel so that the cords from the drive wheel travel in a direct line to the bobbin whorl and the flyer whorl. Hold the drive wheel so it does not move and re-tighten the nuts.

STEP 7. ATTACH THE FOOTMAN TO THE CRANK

Single Treadle Wheel. Remove the footman pin from the footman. Place the keyhole at the top of the footman onto the outer end of the crank. Secure by inserting a footman pin into the hole at the top of the footman. Note: The ball end of the footman pin should be higher than the exit end.

Double Treadle Wheel. Remove the footman pin from the top of each footman. Hook the keyhole of the footman attached to the pedal closest to the rear leg onto the center (lower) pivot of the crank. Hook the keyhole of the footman attached to the pedal nearest the front leg onto the outer end of the crank. Secure each footman by inserting a footman pin into the hole at the top of the footman. Note: The ball end of the pin should be higher than the exit end.

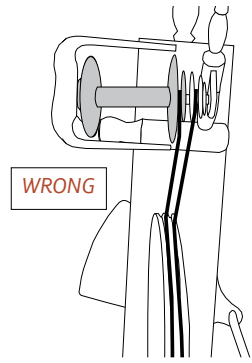
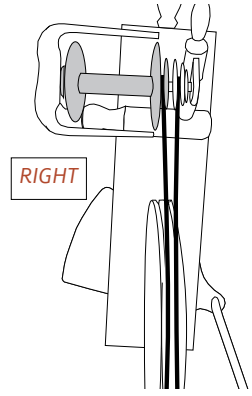

DRIVE WHEEL ALIGNMENT

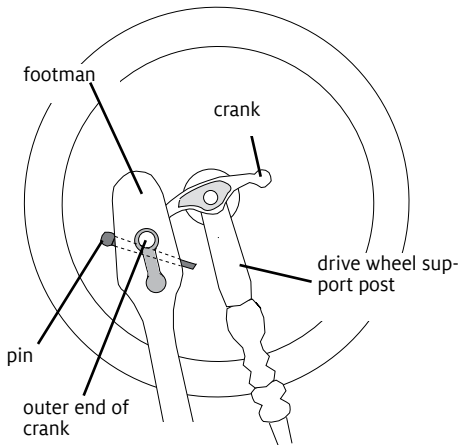

SINGLE TREADLE FOOTMAN

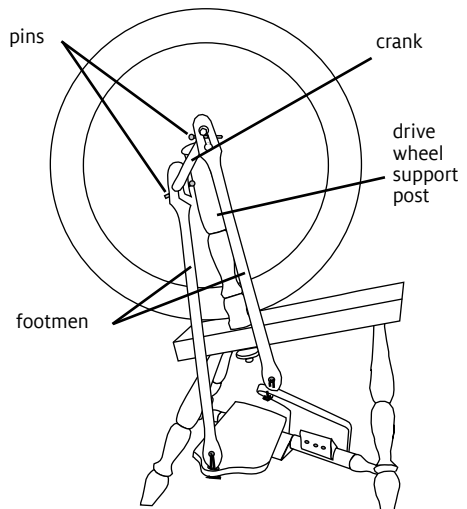

DOUBLE TREADLE FOOTMAN

STEP 8. SET UP THE DRIVE MODE

Double Drive

Place one loop of the drive band in the bobbin whorl on the bobbin and the second loop in one of the grooves on the flyer whorl. Insert each loop in its corresponding groove on the drive wheel. Turn the drive wheel clockwise one full turn until the loops settle into the drive wheel grooves.

Scotch Tension

Place both loops of the drive band in one of the grooves on the flyer whorl. Turn the drive wheel clockwise one full turn until the loops settle into a groove on the wheel. Insert the rosewood peg and thumbscrew into the holes in the MOA base. Put the thumbscrew in the hole closest to the front of the wheel.

To install the Scotch tension band, hook the spring onto the brass hook on the side of the base of the MOA. Place the cord over the bobbin whorl, under the rosewood peg on the MOA and lastly through the hole in the rosewood thumbscrew. Secure the end of the cord and tighten the thumbscrew as needed. Remember, in this mode the double drive cord is placed over the bobbin whorl only.

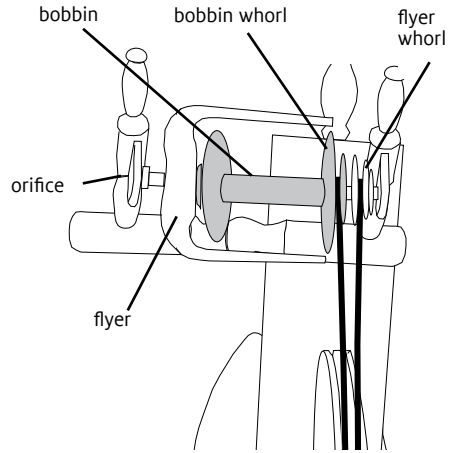

DOUBLE DRIVE MODE - TOP VIEW

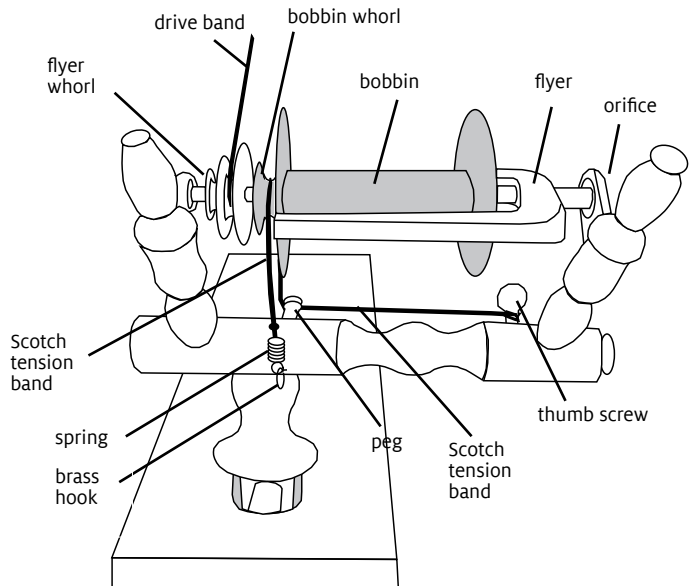

SCOTCH TENSION MODE - FRONT VIEW

MAINTENANCE NOTES

Schacht-Reeves Spinning Wheels are constructed of the finest grades of white ash or cherry wood. All our wood has been kiln dried to assure its stability under a variety of conditions. Wood is a natural, breathing material, and like any natural material it is affected by its environment. Avoid placing your wheel near direct sunlight. Heat concentrated on parts of the wheel can cause them to dry out and shrink. This shrinkage can cause weakness in the joints and warping of parts. Place your wheel where it will be free of damp air, as this can make wood swell and cause the moving parts to stiffen and function inefficiently. A regular schedule of care and maintenance will ensure you and your Schacht-Reeves wheel many productive years together.

quired to protect it from oil and moisture. The rest of the wheel has been finished with Danish oil that penetrates into the wood, protecting the wood as well as the surface. If you need to touch up small chips or scuffed areas on your wheel, lightly sand the area and apply a small amount of Danish oil using a soft, lint-free rag. (Use either Deft or Watco Danish oil, natural color, available at most hardware stores. Carefully follow the directions on the container. Caution: Because of the danger of spontaneous combustion, be sure to clean and dispose of the applicators and oily rags according to the manufacturer's instructions.)

CARE AND MAINTENANCE CHECKLIST

- 1. Periodically clean excess fibers from all parts of your wheel.**
- 2. Check screws for tightness.**
- 3. Lubricate the moving parts.**

Before leaving the factory, your wheel was lubricated and tested. Keeping the moving parts oiled will ensure that your wheel is operating as efficiently as possible. After every few hours of spinning, use a drop of oil on the parts noted in the illustration.

Use medium-weight oil, such as 20 or 30 weight motor oil.

To lubricate the leather bearings, use a paste wax such as carnuba.

Paste wax can also be applied to the crank where the leather touches the footman, to minimize any noise.

- 4. Protect the finish on your spinning wheel.**

The flyer has been lac-

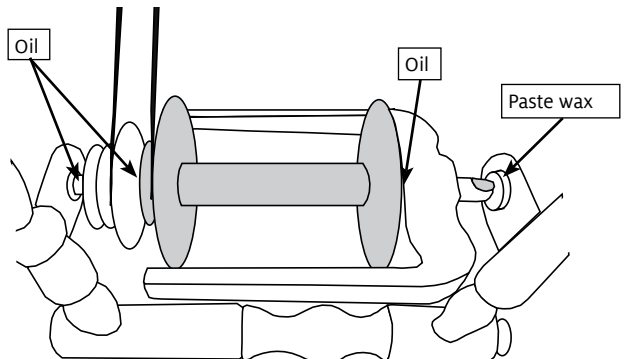

USING YOUR SCHACHT-REEVES SPINNING WHEEL

Spinning in double drive mode

In double drive mode, the drive band is a continuous doubled loop that drives both the flyer and the bobbin. One loop is placed over the flyer whorl and into a groove on the drive wheel, while the other loop is placed over the bobbin whorl and into the remaining drive wheel groove. The speed of the flyer is determined by the size of the whorl: the smaller the whorl, the faster the flyer spins. The take-up rate of the yarn depends in part on the difference in size between the flyer whorl and the bobbin whorl.

The main factor determining the rate of take-up is the amount of tension on the drive band, which is controlled by the drive band tension knob. The looser the tension, the slower the take-up; the greater the tension, the faster the take-up. To increase the tension and therefore the take-up rate, screw the tension knob clockwise. This will move the MOA farther from the drive wheel and increase the tension on the drive band. You can also increase or decrease the rate of take-up by varying the speed of your treadling.

Spinning in Scotch tension mode

Scotch tension employs two tension adjustments as opposed to the single tension adjustment used for the double drive mode. First, insert the rosewood peg and thumbscrew into the holes in the MOA base.

Use the same drive band that is used for the double drive mode, but place both loops over the flyer whorl and into one of the drive wheel grooves. (A single drive band can be substituted, if desired.) The Scotch tension band acts as a brake on the bobbin. One end of the band attaches to a spring on the base of the MOA, goes over the bobbin whorl, around the rosewood peg and fastens to the rosewood thumbscrew on the side of the MOA base.

The tension knob at the front of the wheel controls the drive band that runs the flyer whorl; the Scotch tension thumbscrew controls the Scotch tension band that runs the bobbin.

It can be difficult to determine which knob to use to control the rate of take-up. The best way to begin is to loosen both the drive band and the Scotch tension band. Adjust the drive band first: Begin treadling and tighten the drive band with the drive band tension knob until the flyer begins to turn. Then adjust the Scotch tension band. Attach a leader of yarn to the bobbin, hold the leader and start treadling. Tighten or loosen the Scotch tension band with the thumbscrew until the pull on the yarn seems comfortable. A tension that is too loose will result in overtwisted yarn. While spinning, adjust the rate of take-up using the rosewood thumbscrew, rather than the drive band tension knob.

WHORLS: WHAT ARE THE DIFFERENT WHORL RATIOS AND WHAT DO THEY MEAN?

The rule of thumb is: The larger the whorl, the slower the speed of take-up; the smaller the whorl, the faster the speed of take-up. For example, if you find that your yarn is drawing in faster than you would like, and you have already adjusted the tension, then change to a bigger whorl to slow things down.

To understand whorl ratios, you need to understand how your wheel works. Notice that when the treadle goes up and down one time, the drive wheel goes around once. At the same time, the flyer is spinning around. The number of times the flyer goes around compared to one turn of the drive wheel is the drive ratio. A drive ratio of 7:1, for example, means that for each time the drive wheel goes around, the flyer spins around 7 times.

How do you know which whorl to use? The higher the whorl ratio, the faster the flyer will spin, and the more twist will transfer to the yarn. Your choice of whorl size will depend on the fiber you're spinning, your treadling rate and the type of yarn you want. There are no hard and fast rules for picking a whorl. What matters is that you choose a whorl that helps your wheel do as much of the work for you as possible. In general you will choose a larger whorl for coarse fiber to produce a thicker yarn; and you will choose a smaller whorl for fine fiber to produce a thinner yarn. Two whorls come with each wheel. Each whorl has two ratios - see the chart below.

REMOVING THE WHORL

The whorl is threaded in a reverse direction. To remove the whorl, hold the flyer vertically with the whorl on top, and turn the whorl in a *clockwise* direction.

REPLACING THE DRIVE BAND

To install a new drive band, first unscrew the drive wheel support nuts that hold the wheel supports to the base, then lift both supports and the wheel out of the base. Place the doubled cord between the supports, reinstall the supports and secure with the nuts. Next, remove the flyer assembly, place the loops over the flyer and bobbin whorls. Reinstall the flyer assembly. Place the drive band loops into the slots in the drive wheel.

SCHACHT-REEVES WHORL RATIOS		
	24" Drive Wheel	30" Drive Wheel
Medium whorl	12 :1 / 15:1	14.5:1 / 18:1
Fast whorl	17:1 / 19.8:1	20.75:1 / 24:1

TROUBLESHOOTING

Flyer won't turn.

The drive band is not over the flyer whorl, or the drive band is too loose.

Yarn won't wind on.

There may not be enough tension. Tighten the drive band or the Scotch tension band. Also, check to be sure that the yarn is not wrapped around a flyer hook.

Yarn takes up too fast.

The whorl ratio is too high. Try a bigger whorl (with a lower ratio) to slow down the wheel, slow down your treadling, or loosen the tension on the drive band.

Yarn doesn't have enough twist.

The yarn is probably being drawn onto the bobbin too quickly. Hold back on the yarn to allow for more twist to be transferred to the yarn, treadle faster, or change to a smaller whorl.

Yarn has too much twist.

This is a common problem for new spinners. Generally, when the yarn overtwists it kinks up and results in yarn breakage. Usually overtwisting is caused by holding the yarn too long before allowing it to take up onto the flyer. Try slowing down your treadling and drawing out the fibers faster so that they can be taken up more quickly. Also, you can try tightening the tension so that the yarn takes up faster.

Bobbin isn't turning on the flyer shaft.

Check to see if the wood of the bobbin has become swollen. First remove the flyer assembly from the wheel and try spinning the bobbin on the shaft with your finger. If the bobbin doesn't turn freely, it needs to be reamed. Call or email the factory for further information.

Treadling is too hard.

The tension on either the drive band or the Scotch tension band is too tight. Loosen and then retighten the tension only enough to make the yarn start to draw in.

Yarn draws in erratically.

If you tied your drive band, check to see that the knot isn't too large or too hard.

TWO YEAR LIMITED WARRANTY

The serial number appears on the brass name plate of your wheel.

Your new Schacht-Reeves Spinning Wheel is warranted to the original consumer purchaser by Schacht Spindle Company, Inc., to be free of defects in material and workmanship. Schacht Spindle Company's obligation under this Warranty shall be limited to the repair or replacement of any part or parts which may prove defective within two (2) years following the date of original purchase by the consumer, and which Schacht Spindle Company's examination shall disclose to our satisfaction to be thus defective.

If a problem with this Schacht Spindle Company product develops during the warranty period, first contact the Schacht Spindle Company dealer from whom you made the purchase. If the problem cannot be handled through your dealer, then contact our customer service department. At our option, it may be required that the product be returned to our factory freight prepaid for inspection and repair and/or replacement.

This Warranty covers normal consumer use and does not cover damage that occurs in shipment or damage that results from alteration, accident, misuse, abuse, or neglect.

This Warranty gives you specific legal rights, and you may also have other rights that vary from state to state.