

WOLF HEIGHT EXTENDER STROLLER

FL3053

ASSEMBLY INSTRUCTIONS

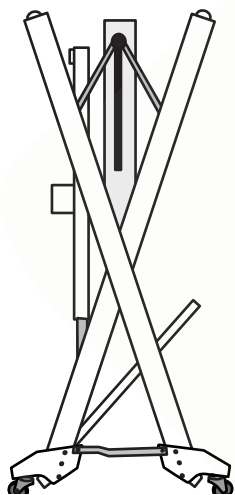

folded—ready to travel

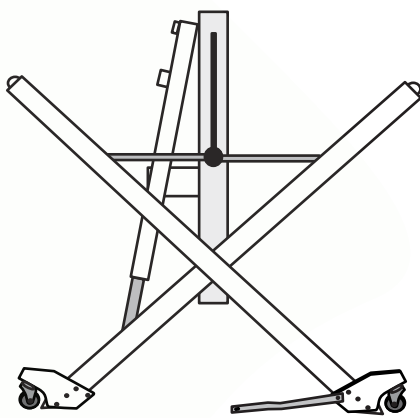

open—ready to weave

FOR INSTALLATION ON ALL HEIGHT EXTENDER WOLF LOOMS

Wolf looms **without** height extender require the Wolf Pup 8.10 Stroller (FL3052) or Wolf Stroller (FL3051). If you received this booklet with FL3052 or FL3051, please visit our website for the correct booklet.



Find out more at schachtspindle.com
Schacht Spindle Company 6101 Ben Place Boulder, CO 80301
p. 303.442.3212 f. 303.447.9273

© 2018 Schacht Spindle Company, Inc.

WOLF HEIGHT EXTENDER STROLLER

ASSEMBLY INSTRUCTIONS

PARTS

- 4 – caster blocks with casters
- 2 – height extender stroller bars
- 4 – 1/4-20 x 1-1/2" Phillips truss head machine screws
- 2 – 1/4-20 x 3-1/2" Phillips truss head machine screws
- 2 – 1/4-20 x 2-1/4" Phillips truss head machine screws
- 2 – 1/4-20 x 4" Phillips truss head machine screws
- 2 – 1/4-20 x 1-3/4" hex bolts
- 2 – 1/4-20 x 1-1/2" hex bolts
- 8 – 1/4" USS flat washers
- 2 – 1/4-20 wing nuts
- 4 – 1/4-20 lock nuts

REQUIRED TOOLS

- #2 Phillips screwdriver
- slotted (flat) screwdriver
- 7/16" or adjustable wrench

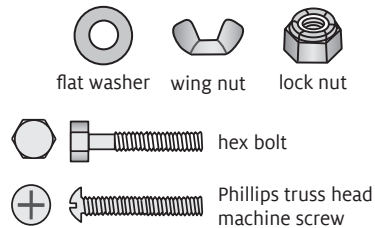

NOTES

- 1. Please read all instructions prior to beginning installation. This instruction booklet contains three different sets of instructions. Be sure that you are following the correct instruction set for your loom before beginning any installation.**
- 2. This kit contains parts to attach a Wolf Height Extender Stroller to any Wolf loom with height extender. Not all of the included parts are needed to attach the stroller to every loom; there may be parts left over when you have finished.**
- 3. The height extender blocks must be installed on your loom before you install the Wolf Height Extender Stroller.**
- 4. Wolf loom legs are called out by where they cross each other. The legs that touch the ground at the front of the loom are called “inside” legs because they are covered by the “outside” legs when they cross at the loom center.**

USING THE STROLLER

1. For traveling: Fold the loom, making sure that the treadles come to rest above the rear leg brace. Tighten the fold knobs and secure the slide lock bars (on bigger looms only) to keep the loom closed. The loom now sits on its stroller wheels (Figures 1A and 1B). Remove the wing nuts on the bolts in the front caster blocks. Place the slots in the stroller bars over these bolts, replace the wing nuts, and tighten.

2. For weaving: Remove the wing nuts from the front caster blocks and detach the stroller bars. Replace the wing nuts and tighten. Loosen the fold knobs one-quarter turn, unfold the loom, and secure the slide lock bars on bigger looms.

Loosening the fold knobs all the way or removing them can cause the loom to collapse, which could result in injury.

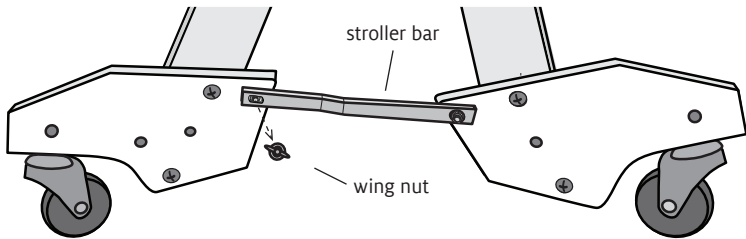

FIGURE 1A: USING THE STROLLER ON A MIGHTY WOLF, BABY WOLF, OR WOLF PUP LT

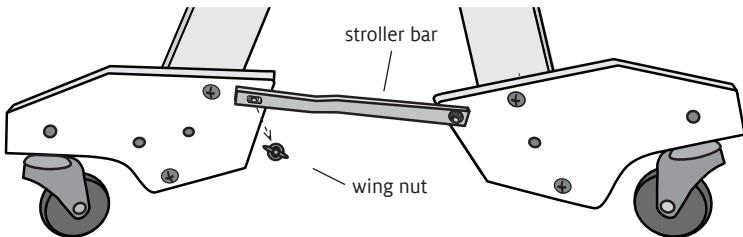

FIGURE 1A: USING THE STROLLER ON A WOLF PUP 8.10

INSTALLATION ON BABY WOLF & MIGHTY WOLF HEIGHT EXTENDER LOOMS

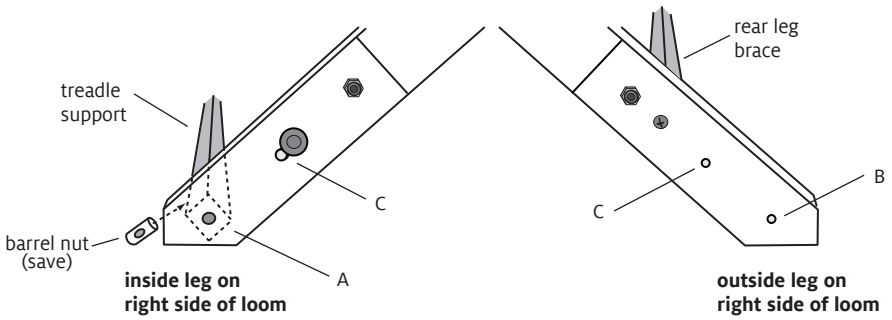

FIGURE 2: MIGHTY WOLF AND BABY WOLF LEGS

1. Install the Wolf Stroller on a hard surface. Open the loom to weaving position (see front cover illustration).
2. Set the treadle support on a block of wood or a few books to elevate the loom front about two inches. Remove the machine screws and barrel nuts that hold the treadle support to the inside legs at hole [A] (Figure 2). Save the barrel nuts for the next step.
3. Set a caster block on the outer side of an inside leg, with the caster wheel toward the front and the floor (Figure 3). Line up hole [D] at the bottom of the caster block to hole [A] in the leg. Insert a 1/4-20 x 3-1/2" Phillips truss head machine screw through the bottom hole [D] in a caster block, then through the bottom hole of an inside leg height extender block (Figure 3). Thread the machine screw into a barrel nut in the treadle support and tighten, using a slotted screwdriver to hold the barrel nut in position. Repeat with a second caster block and the other inside leg.
4. Insert a 1/4-20 x 1-1/2" Phillips truss head machine screw into the top hole [E] of a caster block (Figure 3). The screw will thread into an insert in the height extender block that you cannot

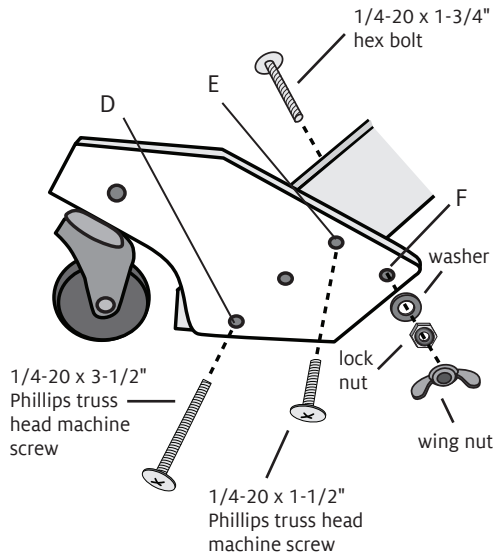

FIGURE 3: FRONT CASTER BLOCK AND INSIDE LEG

see; fasten securely. Repeat for the other caster block.

5. Attach the hex bolt to hold the front of the stroller bar: From the inside of the loom, insert a 1/4-20 x 1-3/4" hex bolt through hole [F] in the front caster block. Secure with a 1/4" washer and a 1/4-20 lock nut. Place a 1/4-20 wing nut on the bolt (Figure 3). Repeat for the other front caster block.

6. Set a caster block on the outer side of an outside leg, with the caster wheel toward the back and the floor (Figure 4). Line up hole [G] at the bottom of the caster block to hole [B] in the outside leg. Insert a 1/4-20 x 3-1/2" Phillips truss head machine screw through the caster block and leg. The screw will thread into an insert in the height extender block that you cannot see; fasten securely. Repeat with another caster block and the other outside leg height extender block.

7. Attach the tops of the caster blocks: Insert a 1/4-20 x 1-1/2" Phillips truss head machine screw into the top hole [H] of a caster block (Figure 4). The screw will thread into an insert in the height extender block that you cannot see; fasten securely. Repeat for the other outside leg height extender block.

8. Attach the stroller bar to the rear caster block: From the inside of the loom, insert a 1/4-20 x 1-1/2" hex bolt through hole [I] in the rear caster block (Figure 5). Place a washer on the hex bolt and then place the round hole at the end of the stroller bar over the bolt so that the jog in the bar points inward. Secure with a 1/4-20 lock nut, using a 7/16" wrench to attach the lock nut. Tighten the lock nut securely enough to hold the stroller bar in place, but loosely enough for it to pivot. Repeat for the other rear caster block. ■

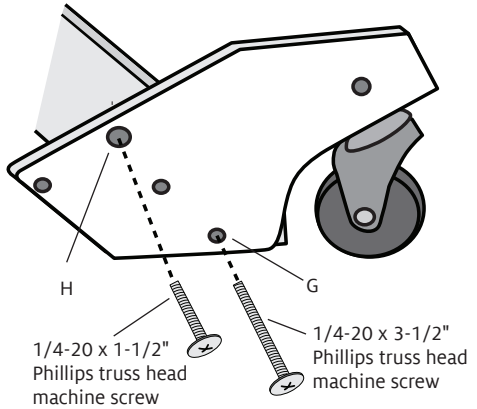

FIGURE 4: REAR CASTER BLOCK AND OUTSIDE LEG

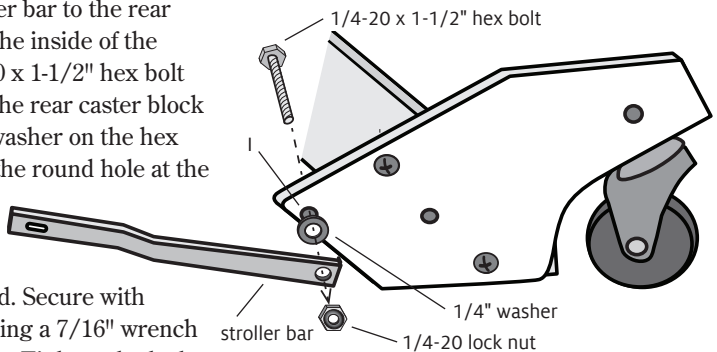

FIGURE 5: ATTACHING STROLLER BAR

INSTALLATION ON WOLF PUP 8.10 & WOLF PUP LT HEIGHT EXTENDER LOOMS

NOTE: If you installed the wheels that came with your loom, we recommend that you take them off before installing your Wolf Stroller.

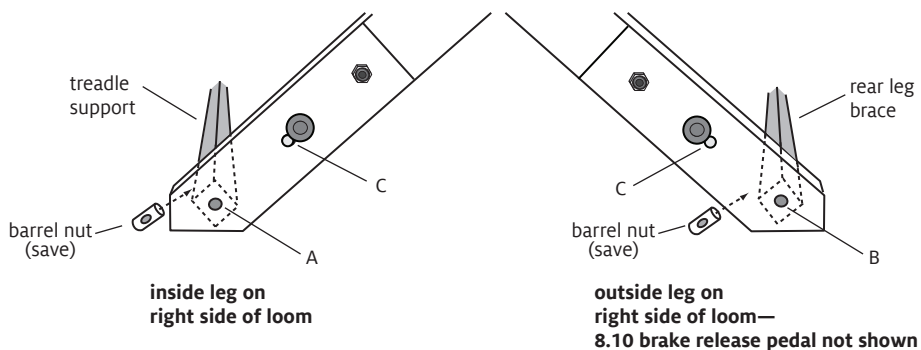

FIGURE 6: WOLF PUP 8.10 AND LT LEGS

1. Install the Wolf Stroller on a hard surface. Open the loom to weaving position (see front cover illustration).
2. Set the treadle support on a block of wood or a few books to elevate the loom front about two inches. Remove the machine screws and barrel nuts that hold the treadle support to the inside legs at hole [A] (Figure 6). Save the barrel nuts for the next step.
3. Install the Wolf Stroller on a hard surface. Open the loom to weaving position (see front cover illustration).
4. Set the treadle support on a block of wood or a few books to elevate the loom front about two inches. Remove the machine screws and barrel nuts that hold the treadle support to the inside legs at hole [A] (Figure 6). Save the barrel nuts for the next step. Set a caster block on the outer side of an inside leg, with the caster wheel toward the front and the floor (Figure 7). Line up hole [D] at the bottom of the caster block

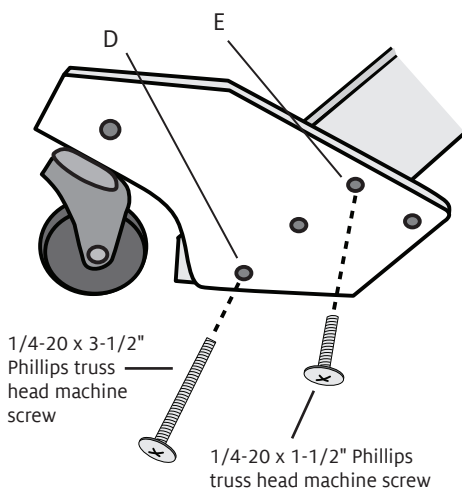

FIGURE 7: FRONT CASTER BLOCK AND INSIDE LEG

to hole [A] in the leg. Insert a 1/4-20 x 3-1/2" Phillips truss head machine screw through the bottom hole [D] in a caster block, then through the bottom hole of an inside leg height extender block (Figure 6). Thread the machine screw into a barrel nut in the treadle support and tighten, using a slotted screwdriver to hold the barrel nut in position. Repeat with a second caster block and the other inside leg.

5. Insert a 1/4-20 x 1-1/2" Phillips truss head machine screw into the top hole [E] of a caster block (Figure 7). The screw will thread into an insert in the height extender block that you cannot see; fasten securely. Repeat for the other inside leg height extender block.

6. Attach the hex bolt to hold the front of the stroller bar: From the inside of the loom, insert a 1/4-20 x 1-3/4" hex bolt through hole [F] in the front caster block. Secure with a 1/4" washer and a 1/4-20 lock nut. Place a 1/4-20 wing nut on the bolt (Figure 8). Repeat for the other front caster block.

7. Set the rear leg brace on a block of wood or a few books to elevate the loom back about two inches. Remove the machine screws and barrel nuts holding the rear leg brace to the outside legs at hole [B] (Figure 6, page 6).

8. Set a caster block on the outer side of an outside leg, with the caster wheel toward the back and the floor (Figure 9). Line up hole [G] at the bottom of the caster block to hole [B] in the outside leg. Insert a 1/4-20 x 4" Phillips truss head machine screw through the bottom hole [G] in a caster block, then through the bottom hole of an inside leg height extender block. Thread the machine screw into a barrel nut in the rear leg brace and tighten, using a slotted screwdriver to hold the barrel nut in

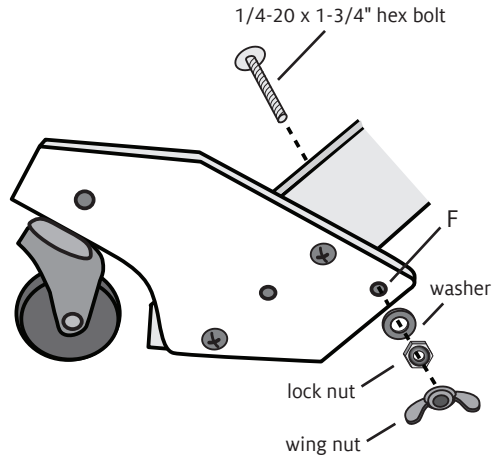

FIGURE 8: STROLLER BAR AND FRONT CASTER BLOCK

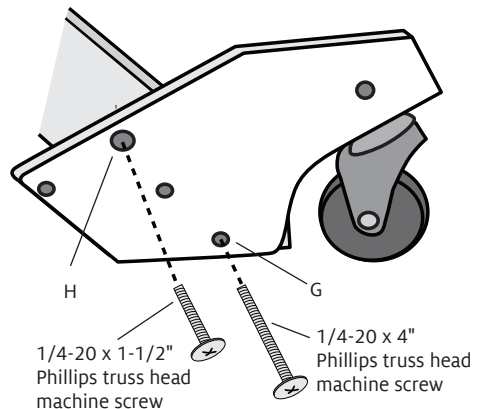

FIGURE 9: REAR CASTER BLOCK AND OUTSIDE LEG

position. Repeat with a second caster block and the other outside leg height extender block.

9. Insert a 1/4-20 x 1-1/2" Phillips truss head machine screw into the top hole [H] of a caster block (Figure 9). The screw will thread into an insert in the height extender block that you cannot see; fasten securely. Repeat for the other outside leg height extender block.

10. Attach the stroller bar to the rear caster block: From the inside of the loom, insert a 1/4-20 x 1-1/2" hex bolt through hole [I] in the rear caster block. Place a washer on the hex bolt and then place the round hole at the end of the stroller bar over the bolt. For Wolf Pup 8.10 looms, the jog in the stroller bar must point *outward* (Figure 10A). For Wolf Pup LT looms, the jog in the stroller bar must point *inward* (Figure 10B). Secure the hex bolt with a 1/4-20 lock nut, using a 7/16" wrench to attach the lock nut. Tighten the lock nut securely enough to hold the stroller bar in place, but loosely enough for it to pivot. Repeat for the other rear caster block. 🍷

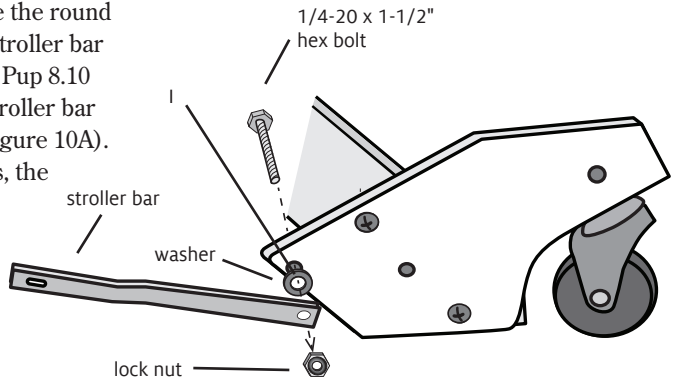

FIGURE 10A: STROLLER BAR ON WOLF PUP 8.10

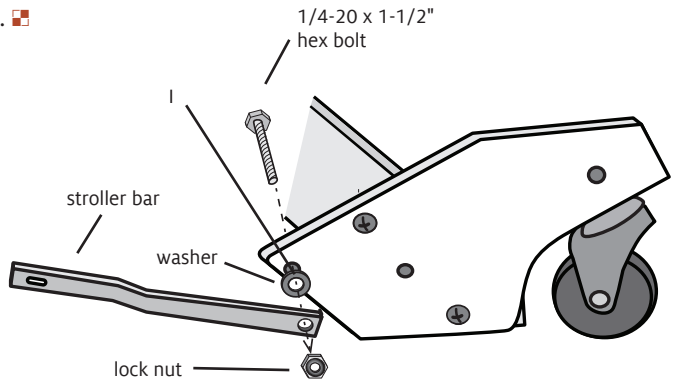

FIGURE 10B: STROLLER BAR ON WOLF PUP LT