

BABY WOLF LOOM™

FL3001 FL3013
FL3003 FL3021
FL3011 FL3023

ASSEMBLY INSTRUCTIONS

PARTS

Wrapped onto warp beam:

- 3X apron bars
- 2X lease sticks (with holes)
- 1X 1/4" treadle aid dowel (8-shaft and 4 Now-4 Later looms only)
- 2X 27" apron cord dowels (cherry looms only)

Accessory pack:

- 1X brass reed hook
- 1X warp beam crank handle
- 1X 3/8" cap nut
- 1X 3/8" washer

- 3X extra 8/32" hex nuts for shafts
- 3X extra rubber O-rings for shafts
- 10X 29" apron cords (or 2X 252" apron cords for cherry looms)

Maintenance and Warranty Manual

4-shaft looms:

- 400X heddles
- 24X tie-up cords

8-shaft and 4 Now-4 Later looms:

- 800X heddles
- 80X tie-up cords
- 10X black treadle aid cords

BEFORE YOU BEGIN

- All Wolf looms assemble in a similar way. Watch the Baby Wolf assembly video on our Youtube channel (www.youtube.com/user/schachtspindle).
- You'll find a complete labelled diagram of the Wolf loom in your Maintenance and Warranty manual and at schachtspindle.com.
- Wolf loom legs are called out by where they cross each other. The legs that touch the ground at the front of the loom are called "inside" legs because they are covered by the "outside" legs when they cross at the loom center.
- The beater is at the front of the loom. The brake is on the right side of loom.

UNFOLDING THE LOOM

1. Remove all plastic wrap from the loom. Remove both shipping braces by slightly loosening the back beam knobs and front beam screws holding them in place. Discard the braces and tighten the knobs and screws.

2. Slightly loosen the black fold knobs on each side of the loom (Figure 1). Generally, a single turn will do.

Loosening the knobs all the way or removing them can cause the loom to collapse, which could result in injury.

3. Stand at the side of the loom. Hold the front and rear beams together slightly. Pull the slide lock bars out toward the back of the loom.

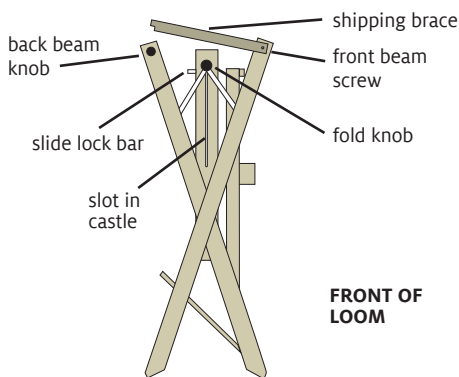

FIGURE 1: UNFOLDING THE LOOM



Find out more at schachtspindle.com
Schacht Spindle Company 6101 Ben Place Boulder, CO 80301
p. 303.442.3212 f. 303.447.9273

© 2019 Schacht Spindle Company, Inc.

4. Continue holding onto the front and rear beams and allow the loom to unfold all the way. If there is a warp on the loom, you may need to hold down the brake release pedal with your foot to loosen the warp as you unfold the loom.

5. When the loom has completely opened, push the fold knobs down to the bottom of the slots in the castle. Tighten the knobs. You can push in the slide lock bars to get them out of the way.

FOLDING THE LOOM

6. To prevent treadles from dragging on the floor when the loom is folded, attach every treadle to at least one tie-up cord.

7. Start folding the loom: Make sure the slide lock bars are pulled out all the way. Loosen the fold knobs one full turn and pull them up in their slots.

8. With one hand on the rear beam and one hand on the front beam, push the loom together as far as it will go.

9. Tighten the fold knobs. Push the slide lock bars in towards the front of the loom.

ATTACHING THE WARP BEAM CRANK HANDLE

10. The warp beam crank handle attaches to a threaded rod on the inside right leg (Figure 2). Locate the washer, cap nut, and the warp beam crank handle in the accessory pack. Place the 3/8" washer and then the metal handle on the rod, with the wooden handle facing out. Secure with the 3/8" cap nut.

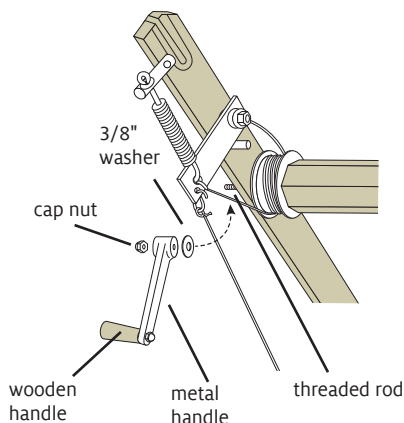

FIGURE 2: WARP BEAM CRANK HANDLE

When you're weaving, the crank should be pushed off of the cap nut. To engage the crank for turning the warp beam, pull the hexagonal hole in the crank onto the cap nut.

ATTACHING APRON BARS

For cherry Wolf looms, see the special instructions for attaching the apron bars.

11. There is one cord for each hole in the cloth and warp beams. Insert one end of a cord through a hole in the beam and pull the cord through. Then insert the other end through the second hole in the end of the cord that you just put through the beam. Pull firmly on the cord to tighten (Figure 3A). Repeat across the cloth beam and the warp beam.

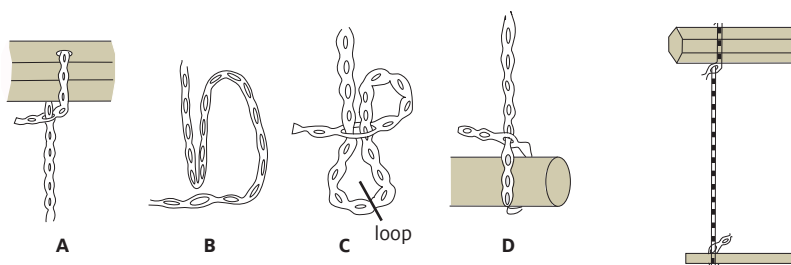

FIGURE 3: INSTALLING APRON CORDS

Visit [youtube.com/user/schachtspindle](https://www.youtube.com/user/schachtspindle) for an apron cord installation video.

12. To attach the apron bar to the apron cords, take a pinch of the cord about 4" from the end (Figure 3B). Insert the pinched cord through the second hole in the cord. Pull on the pinched cord until a new loop forms that is large enough for the apron bar to slip through (Figure 3C). Slide the apron bar through the loop (Figure 3D) and pull tight. Repeat until all cords are attached to the apron bar. Attach the other apron bar to its beam in the same way.

USING THE BEATER PIN

13. The small metal pin attached to the outside right leg holds the beater upright during warping. Push the pin through the hole in the leg and then through the slot in the beater side. Pull out the beater pin and replace it in its holder before weaving or before folding the loom.

INSTALLING HEDDLES

14. Remove the shafts from the loom by removing the rubber O-rings and unscrewing the small hex nuts from the jack pins (Figure 4). Pull the shaft straight up and out of the loom. When you put the shaft back in the loom, be sure to insert the jack pin back into the hole and secure it with the hex nut. Replacing the rubber O-ring is optional.

15. Lay the shaft on a flat surface. Lay two heddle bars next to the heddles. Carefully slide a group of heddles onto the heddle bars. Fit one end of each heddle bar into one of the slots in the shaft frame. Using very gentle pressure, flex the heddle

bar just enough to fit the other end into the slot on the opposing side of the shaft frame. Push approximately half of the heddles to each end of the shaft. Secure the heddle bars into the heddle bar hooks.

16. Put the shaft back in the loom and secure the jack pin with the hex nut. Repeat for the other shafts. Be sure to keep the heddles oriented in the same direction for easier threading.

INSTALLING TIE-UP CORDS

17. Loop one end of each tie-up cord through a hole in the lamm. For 8-shaft and 4 Now-4 Later looms, there is one tie-up cord for every lamm hole. For 4-shaft looms, use only the 6 middle holes of each lamm.

18. Tie shafts to a treadle by slipping a tie-up cord into the slot in a treadle (Figure 5). Work from the front lamm to the rear lamm for each treadle. After you have completed your tie-up, check each treadle by pushing it all the way to the floor and releasing it, making sure that the button

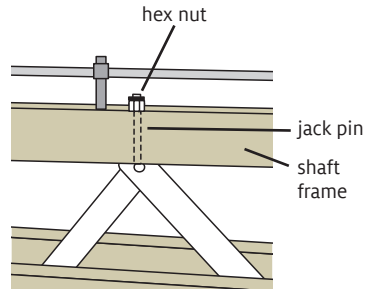

FIGURE 4: JACK PIN ATTACHMENT

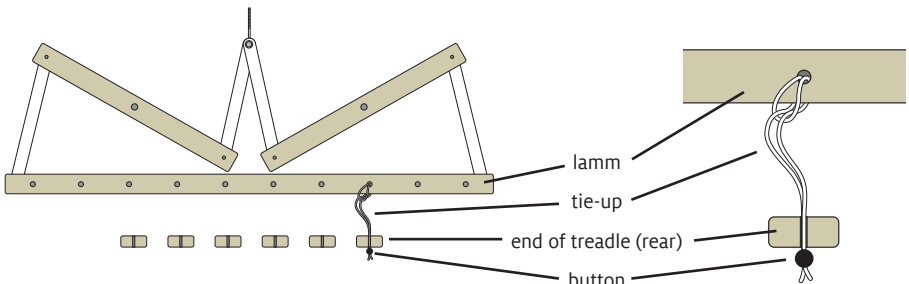

FIGURE 5: INSTALLING TIE-UP CORDS

of each tie-up cord is up against the treadle and that each cord hangs straight down to the treadle.

There is a 1/2" round depression on the underside of each treadle end to prevent the tie-ups from slipping off when the loom is folded.

INSTALLING THE TREADLE AID

(8-shaft and 4 Now-4 Later looms only)

19. The treadle aid prevents shafts from floating. The treadle aid bar is already attached to the rear castle cross brace. Install the 1/4" treadle aid dowel and 10 treadle aid cords onto this bar: Starting at one end of the bar, push a treadle aid cord up through one of the holes (an opened paper clip can be most helpful) and loop it over the 1/4" dowel (Figure 6). Continue across the entire treadle aid bar. After you attach tie-up cords to the treadles, attach treadle aid cords in the same way. We recommend using a treadle aid cord on all of the treadles.

ADJUSTING THE FRICTION BRAKE

20. The friction brake can be adjusted by tightening or loosening the eye bolt (Figure 7). This will increase or decrease the tension on the spring, which will in turn increase or decrease the tension on the brake bar and the brake cable.

Always press down on the brake pedal while you are winding on the warp or advancing the warp on the cloth beam.

REMOVING THE BACK BEAM

21. The back beam can be removed for better access to the heddles when you thread the loom. Loosen the back beam knobs on each side of the back beam and lift the beam out (Figure 8). To replace the back beam, slide it back into the legs and tighten the knobs.

When moving the loom, be sure to lift it using the cloth and warp beams, not the front and back beams.

ADJUSTING THE BEATER

22. The height of your beater has been set at the factory to accommodate most weaving situations. If you want to raise or

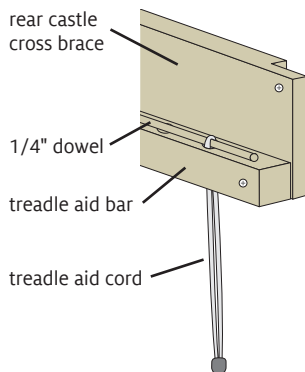

FIGURE 6: TREADLE AID

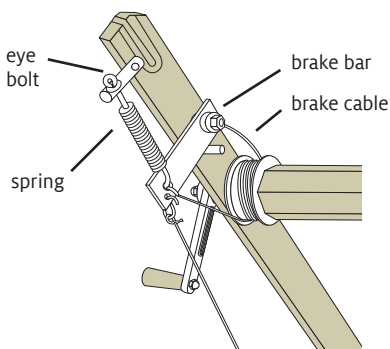

FIGURE 7: FRICTION BRAKE

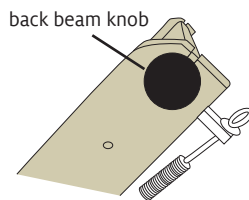

FIGURE 8: BACK BEAM

lower the beater, loosen the two nuts on the inside of each of the metal beater supports. Position the beater at the desired height and tighten the nuts. Be sure that you have set both beater sides at the same height. ■