

CRANBROOK LOOM TENSION BOX RAIL

ASSEMBLY INSTRUCTIONS

PARTS LIST:

- 1 – tension box rail
- 2 – side rail supports
- 2 – tension rail uprights
- 4 – #12 x 1-3/4" flathead screws (older looms only)
- 4 – 1/4" x 2" carriage bolts
- 4 – 1/4" washers
- 4 – 1/4" lock nuts
- 4 – Black knobs (new looms only)
- 4 – 1/4" x 2" truss head machine screws
- 4 – barrel nuts

ASSEMBLY

- Attach a tension rail upright to each side rail as shown in figure 1, using the 2" carriage bolts, washers and lock nuts. Be sure that the completed side rail assemblies are mirror images of each other.
- Attach the tension box rail to the side rail support assemblies using two machine screws and two cross dowel connectors, being careful to position the tension bar rail with the slot facing up.
- Attach the completed tension box rail assembly to the loom sides with the black knobs.

TO ATTACH THE TENSION BOX RAIL TO OLDER MODEL CRANBROOKS

- Measure from the floor up 34-1/2" on the mid and rear frame uprights.
- Mark and drill a 3/16" pilot hole in the center of each upright the outside of the frame. Be sure that the holes in the frame match those in the side rail assembly. These holes should be 17-3/4" apart. *Do not drill all the way through the frame.*
- Attach the side rail supports with #12 x 1-3/4" screws. See figure 2.

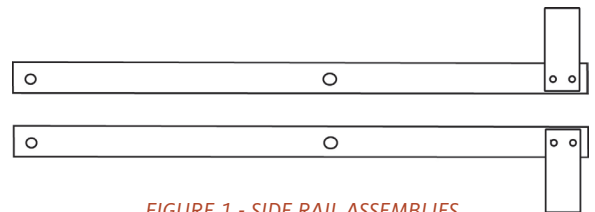

FIGURE 1 - SIDE RAIL ASSEMBLIES

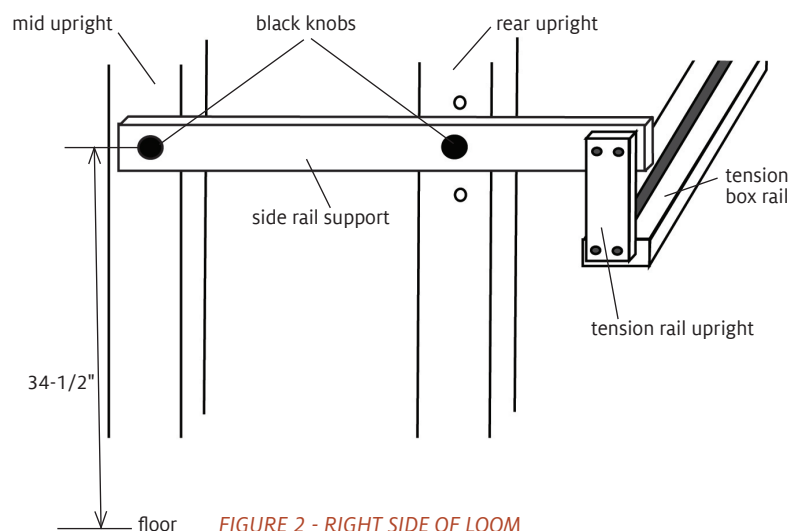

FIGURE 2 - RIGHT SIDE OF LOOM



Find out more at schachtspindle.com
Schacht Spindle Company 6101 Ben Place Boulder, CO 80301
p. 303.442.3212 f. 303.447.9273

© 2013 Schacht Spindle Company, Inc.